

## Application Notes & Product Data Sheet

### *I: Introduction*

Lithium has become a generic term representing a family of battery systems in which Lithium metal is used as the active anode material or negative electrode. Variations in the cathode material, or positive electrode, and the cell electrolyte result in hundreds of possible combinations of Lithium batteries. Rayovac® Lithium Carbon-monofluoride (BR) batteries are a solid-cathode type which optimizes reliability, safety, cost and performance.

### *II: Features*

- Outstanding shelf life and excellent performance over a wide temperature range
- Stable discharge voltage
- High energy density and voltage (3V)
- Enhanced safety by the use of Carbon-monofluoride electrode material and a non-corrosive, non-toxic electrolyte
- Excellent leak resistance
- Shelf life of ten years or more
- Pre-tinned terminals are solderable
- Available with many wave-solderable terminal configurations

### *III: Quality Systems Certification*

CERTIFIED  
ISO 9001



Accredited by the Dutch Council for Certification for certification and registration activities.



## Lithium Carbon-monofluoride (BR) Coin Cells and FB Encapsulated Lithium Coin Cells

### *IV: Applications*

The following devices are examples of good uses for BR coin cells:

- Computer Memory and Real Time Clock Backup
- Electronic Counters, Process Controllers
- Portable Instruments
- Time/Data Protection
- Industrial Controls
- Electronic Gas, Water and Electric Meters
- Communication Equipment
- Tire Pressure Monitoring Systems (TPMS)
- RF Tags, Toll Tags, and ID Tags
- Portable Electronic Devices

### **Application Considerations**

Rayovac® BR coin cells and batteries should be considered for applications that are characterized by a need for:

- Miniaturization
- Leakage resistance
- Lightweight
- Shock and vibration tolerance
- Low to moderate current drains
- Environments requiring extended operation or storage at a wide range of temperatures
- The need for flat discharge voltage and consistent source impedance
- Long shelf life
- An extended service life due to low self-discharge rate
- Enhanced safety and reduced product liability concerns
- U.L. recognized components

## V: Construction

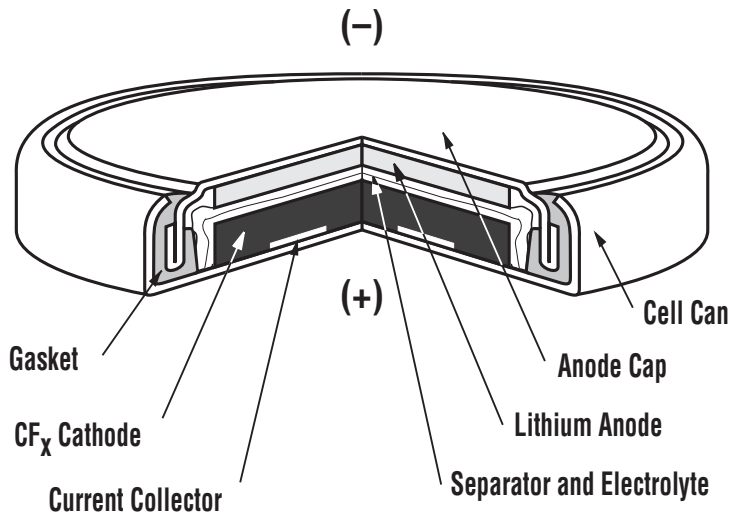

## VI: Battery Selection

### Component Class Batteries and Cells

Today's circuit designers recognize the capabilities of BR Lithium coin cells and FB batteries to function as permanent components in their circuits. FB batteries exhibit reliability rates similar to diodes and resistors. The combination of very low power Complementary Metal-Oxide Semiconductor (CMOS) memory devices with high energy, long life batteries now allow for batteries to be used as life-of-product components.

The traditional approach to product design is to provide sufficient energy to meet a design target for a stated period, at which time the batteries would be replaced. The decision to provide component or expendable power is fundamental to the product concept of the device being powered. Component batteries allow the designer to increase the reliability and functionality of the device by eliminating the need for consumer replacement of batteries. Component batteries eliminate the problems of reversed polarity, wrong chemical system, mismatched capacities, and higher operating costs. However, component batteries require careful selection. The batteries must assure adequate energy for the expected load to compensate for self-discharge and the thermal environment expected, and the batteries must also have a high reliability connection to the circuit.

Today's demand for high performance, small footprint, reliable, and cost-effective electronic products can be realized by identifying the best match between the battery and its application. To do so requires a good

understanding of the device's power requirements and the environment in which it is used as well as how the battery reacts to those loads and environments.

It is important that the battery be considered early in the design process. This will allow the optimization of battery life through the selection of power conserving circuit components. Moreover, early battery selection will also minimize circuit and mechanical layout changes later in the design process.

The following is a list of basic application characteristics and conditions that must be considered for an optimum selection of a lithium Carbon-monofluoride power source.

### Electrical Characteristics

- Voltage: maximum/minimum
- Current drain
- Pulse currents
- Pulse time/frequency of occurrence

### Application Goals

- Duty cycle
- Service life goal
- Shelf life goal
- Reliability
- Safety
- Battery availability

### Packaging

- Shape
- Terminals
- Weight
- Contact materials
- Case materials

### Environmental

- Operating temperature range
- Storage temperature range
- Humidity
- Shock and vibration
- Atmospheric pressure

## VII: Calculating Battery Life

The design of an electronic circuit powered by a component class battery requires the designer to consider two interacting paths that determine a battery's life: consumption of active electrochemical components and thermal wear-out.

To optimize battery life in powered devices, today's designers are first selecting power conserving circuit components, and then specifying high reliability component Lithium batteries. Battery selection is based on an understanding of the thermal capabilities, effects of the operating environment, and the battery life requirements of the powered device.

**Figure 1**, at right, gives an estimate of years of service at various discharge currents for BR Lithium coin cells at room temperatures.

### Consumption of Active Battery Components

Batteries produce electrical current by oxidation and reduction of their active electrochemical components. Once these components are consumed, the battery ceases to produce current. The sum of the energy consumed by the circuit over its expected life plus the electrochemistry's inherent loss of energy due to self-discharge, represents the first path in determining battery life.

### Thermal Wear-Out

The second path in determining battery life is thermal wear-out, which is the loss of capacity caused by thermal mechanisms. Generally, thermal wear-out rates accelerate as temperatures in the operating environment rise.

It is very important to hold the paths of self-discharge and thermal wear-out as separate issues. This is because self-discharge can sometimes be compensated for by increasing the specified battery capacity, while thermal wear-out can only be addressed by selecting a more thermally capable battery.

### Drain vs. Duration

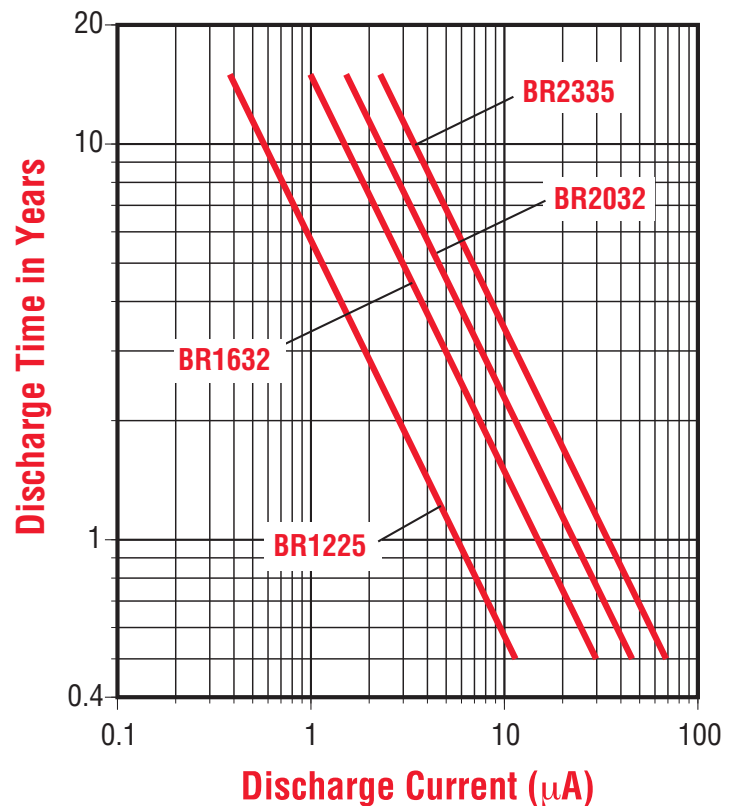

Figure 1

### Battery Life and Capacity Estimates

Rayovac® has accumulated over 200 million device hours of accelerated reliability testing with a major semiconductor manufacturer. This data has allowed us to gain a better understanding of the time and temperature dependent wear out of BR Lithium coin cells and FB batteries during storage. Please contact Rayovac's OEM Division for more information.

## VIII: Performance Characteristics

### A. System Self-Discharge Comparison

BR Lithium Carbon-monofluoride cells offer substantially lower self-discharge rates compared to other battery chemistries. **Figure 2** compares the capacity loss due to self-discharge over a range of temperatures for various battery chemistries. BR Lithium coin cells provide self-discharge rates of less than 0.3% per year and Lifex FB™ batteries less than 0.2% per year.

### System Self-Discharge Rate vs. Temperature

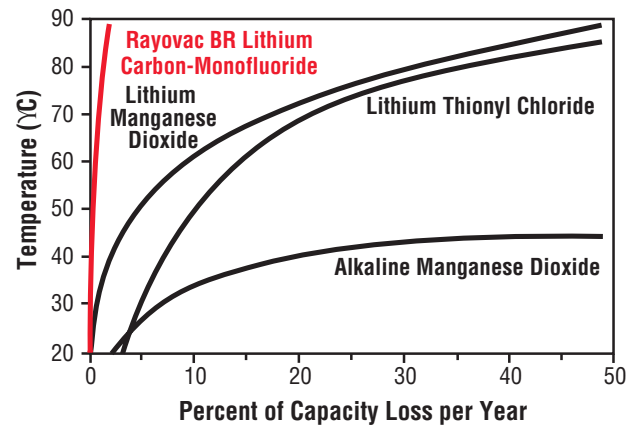

Figure 2

### B. Thermal Wear-Out

At high temperatures, Rayovac's BR Lithium coin cells and FB batteries offer significantly lower failure rates over competing coin cells. **Figure 3** shows the relationship between temperature and the years to 1% failure of 12.5mm diameter cells of-similar capacity. A failure is defined as a closed circuit voltage less than 2.0 volts on a 250Kff load of 0.5 second duration.

### Lithium Coin Cells Temperature/Life Relationship

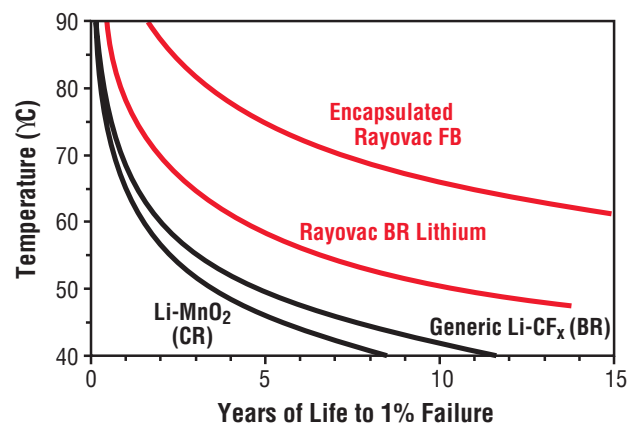

Figure 3

### C. System Internal Resistance Comparison

Rayovac® BR Lithium coin cells provide more stable internal resistance throughout discharge compared to lithium manganese dioxide coin cells as shown in **Figure 4**. This is due to the formation of conductive carbon as a discharge by-product in the cell cathode during discharge. This carbon prevents a change in internal resistance until the active components of the cell are consumed.

### Internal Resistance During 30KΩ Discharge BR2032 Cell vs. CR2032 Cell

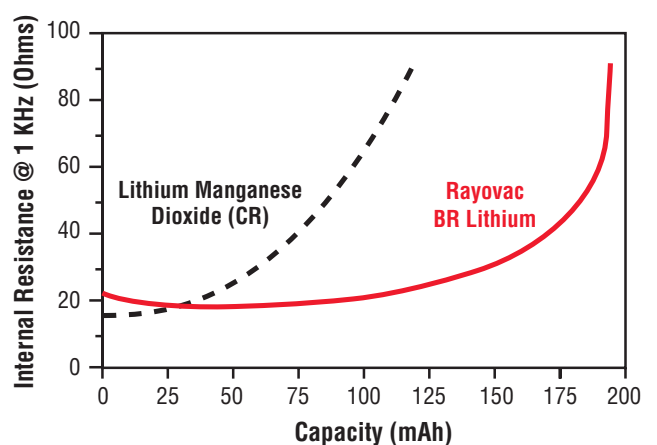

Figure 4

## D. Internal Operating Resistance During Discharge

Figure 5 (right) shows how the internal resistance and voltage changes on a BR1225 cell as a percent of discharge. Similar profiles with slightly different values are observed with other cell sizes. The typical initial 1KHz AC internal resistance for each cell size is shown in Figure 6.

### Typical Initial Internal Resistance at 1 KHz AC

Cell Size	Internal Resistance (Ohms)
BR1225	85
BR1632	34
BR2032	25
BR2335	21

Figure 6

## Internal Resistance and CCV of BR1225 Cell During 30KΩ Discharge

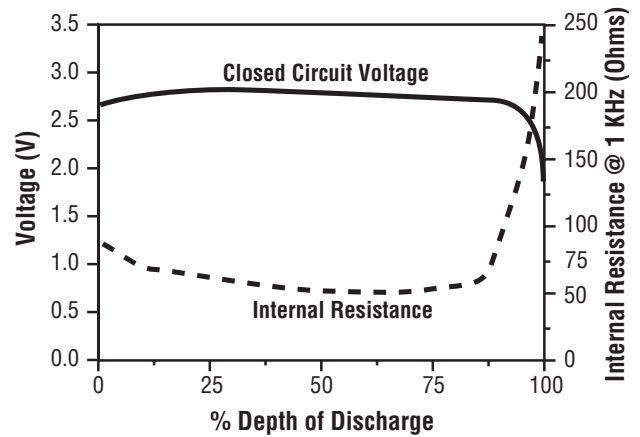

Figure 5

## E. Operating & Storage Temperature Range

Rayovac® BR Lithium coin cells and FB batteries provide excellent performance over a wide range of temperatures. The operating and storage temperature ranges are:

BR Lithium Coin Cells	-40° C to +85° C -40° F to +185° F
FB Batteries	-40° C to +100° C -40° F to +212° F

## F. Safety

Figure 7 below compares the safety of the three most common Lithium systems. The figure demonstrates that the Rayovac® BR Lithium battery components are extremely safe.

Rayovac® BR Lithium batteries have been granted U.L. Component Recognition (file no. MH12542). The battery's components are both chemically and thermally stable before, during, and after discharge. The electrolyte is both non-corrosive and non-toxic.



RECOGNIZED UNDER THE COMPONENT PROGRAM OF UNDERWRITERS LABORATORIES® INC.

### Safety Comparisons of Lithium Systems

Figure 7

Battery System/ IEC Nomenclature	Class	Cathode Material	Cathode Properties	Electrolyte Salt Material	Electrolyte Salt Property	Electrolyte Solvent
Lithium Carbon-Monofluoride Li/(CF) <sub>x</sub> BR	Solid Cathode	Poly-Carbon Monofluoride	Solid Stable	Lithium Tetra Fluoroborate LiBF <sub>4</sub>	Stable	Propylene Carbonate & 1,2 Dimethoxyethane (PC & DME)
Lithium Manganese Dioxide Li/MnO <sub>2</sub> CR	Solid Cathode	Manganese Dioxide	Solid Stable	Lithium Perchlorate LiClO <sub>4</sub>	Explosive	PC & DME
Lithium Thionyl Chloride LiSOCl <sub>2</sub>	Solid Cathode	Thionyl Chloride	Liquid Toxic Corrosive	Lithium Tetra Chloroaluminate LiAlCl <sub>4</sub>	Corrosive	Thionyl Chloride (SOCl <sub>2</sub> )

## G. Charging Characteristics

Although any charging of BR Lithium cells is to be avoided, some charging may occur even in a well designed electrical circuit due to leakage current of the protecting diodes. The diode used in a circuit design with a BR Lithium cell should minimize leakage to within 3% of the rated capacity of the cell over the lifetime of the cell's use. **Figure 8** below provides the maximum total charge allowance for all cell sizes. **Figure 9**, which illustrates these limits as they apply to the BR1225 cell size at various drain rates, follows.

### Maximum Total Charge Allowance

Cell Size	Rated Capacity	3% of Capacity
BR1225	50 mAh	1.50 mAh
BR1632	130 mAh	3.90 mAh
BR2032	195 mAh	5.85 mAh
BR2335	300 mAh	9.00 mAh

Figure 8

### Formula to calculate charge current:

$$I_{\max} (\text{nA}) = \frac{114.15 \times c}{t}$$

- Where:  $I_{\max}$  = Maximum allowable charge current in nanoAmperes (nA)  
 $c$  = Maximum total charge capacity in mAh from table above  
 $t$  = Time on charge in years

### Maximum Total Charge Allowance

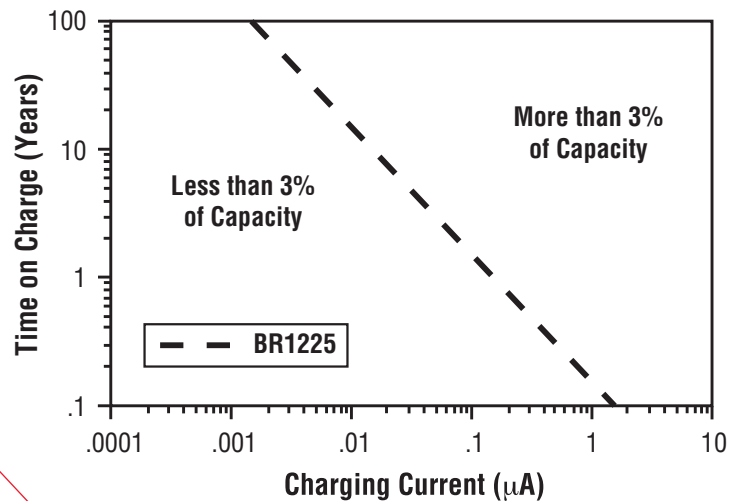

Figure 9

## H. High Altitude Exposure

It is possible for components to be exposed to reduced pressures during shipment by air. Rayovac® BR Lithium batteries that were tested at reduced pressures of 3 mm mercury for 10 days and then discharged at normal rates exhibited the following results:

1. No change in cell appearance.
2. No observed leakage.
3. No change in resulting capacity.

## I. Leakage Resistance

The electrolyte in BR Lithium batteries is based on an organic solvent instead of a corrosive alkaline or acidic solution found in most conventional batteries. This greatly improves the cell's leakage resistance and guards against the negative effects caused by leakage.

## J. Orientation

Since Rayovac® batteries use solid active components, the performance characteristics described are obtained regardless of the installation position.

## IX: Product Specifications

### BR Lithium Coin Cell

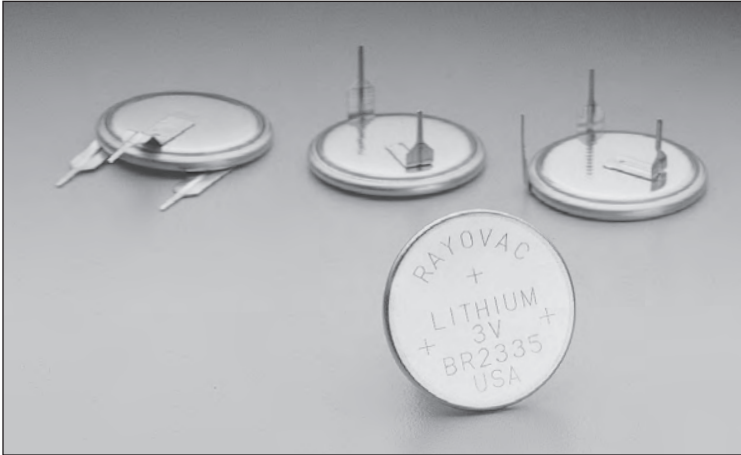

#### A. Specification Table

Rayovac® BR Lithium coin cells are available in a wide variety of tab and pin mounting configurations. See Product Availability Table (page 14) for a list of the most popular items.

Part Number	Rated Nominal Capacity (mAh)	Nominal Pulse Capability (mA*)	Dimensions				NEDA Number	IEC Number
			Diameter (mm)	Height (mm)	Weight (g)	Volume (cc)		
BR1225	50	5	12.5	2.5	0.8	0.30	5020LB	BR1225
BR1632	130	10	16.0	3.2	1.6	0.63	Not Assigned	BR1632
BR2032	195	10	20.0	3.2	2.4	1.00	5004LB	BR2032
BR2335	300	10	23.0	3.5	3.4	1.45	Not Assigned	BR2335

Figure 10

## B. Typical Discharge Curves

### BR1225

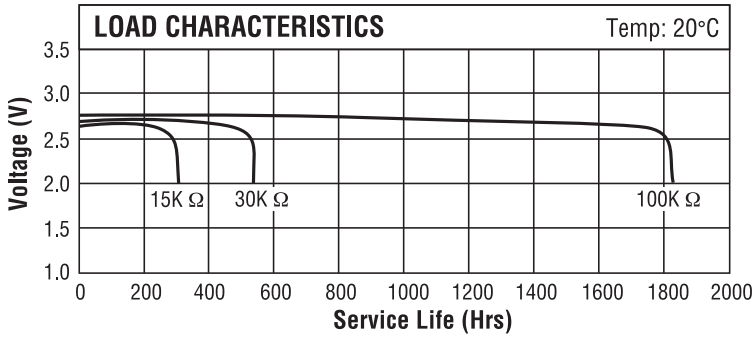

Figure 11

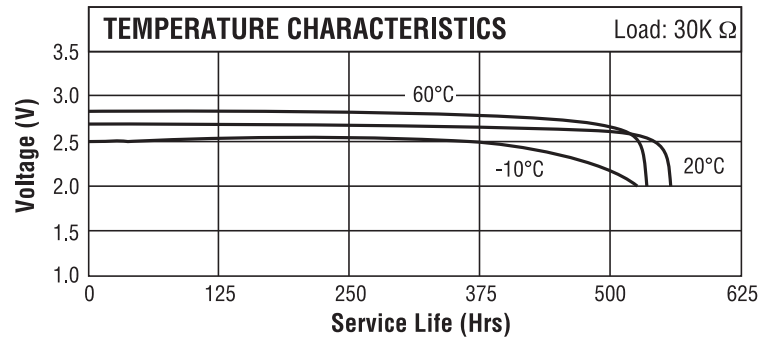

Figure 12

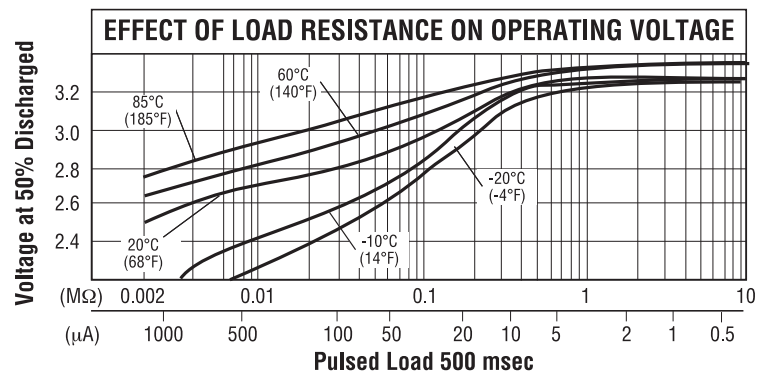

Figure 13

### BR1632

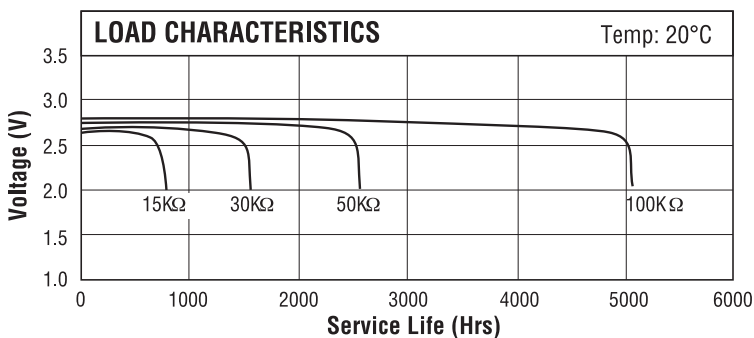

Figure 14

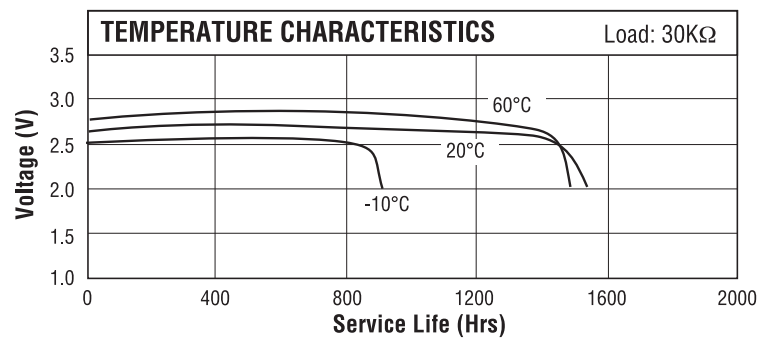

Figure 15

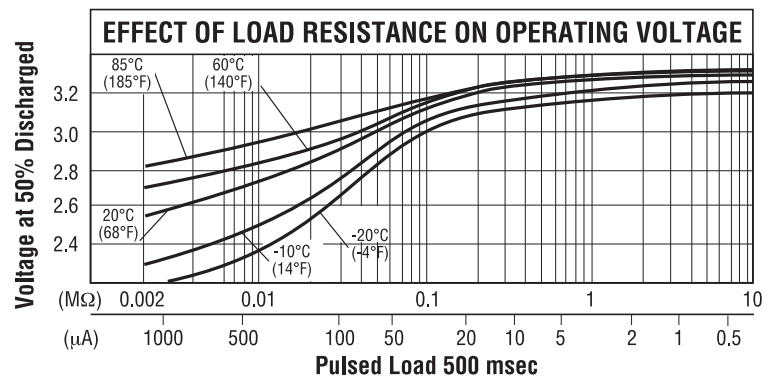

Figure 16



### BR2032

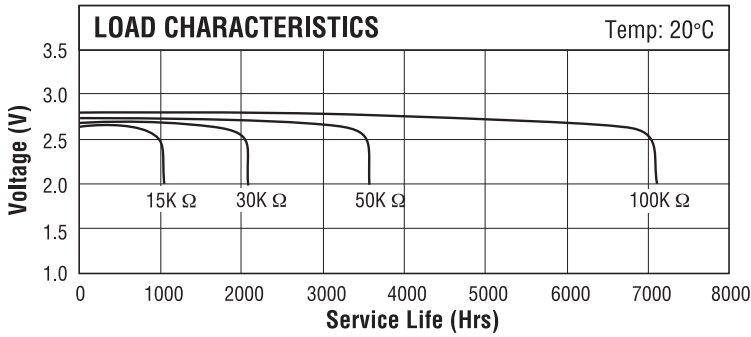

Figure 17

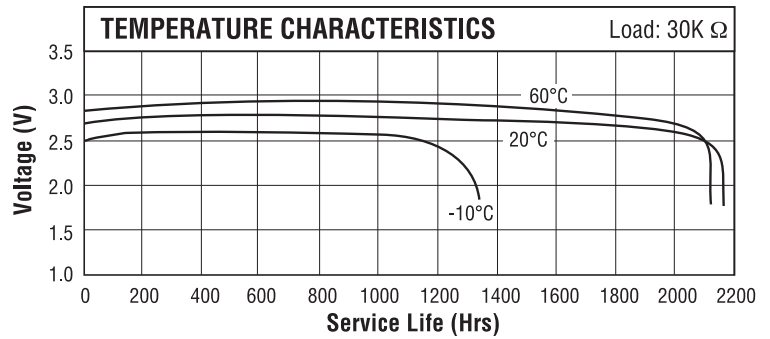

Figure 18

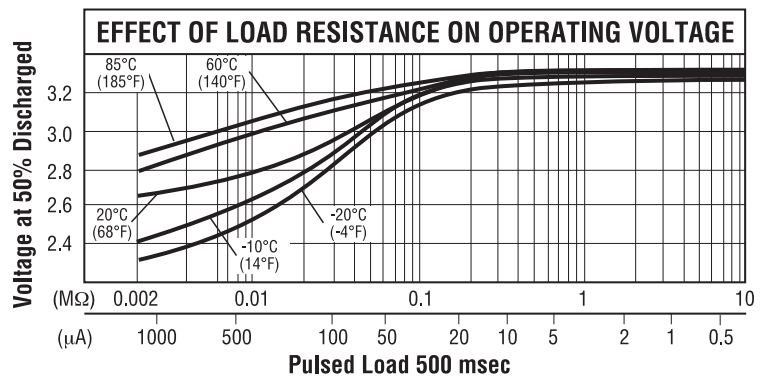

Figure 19

### BR2335

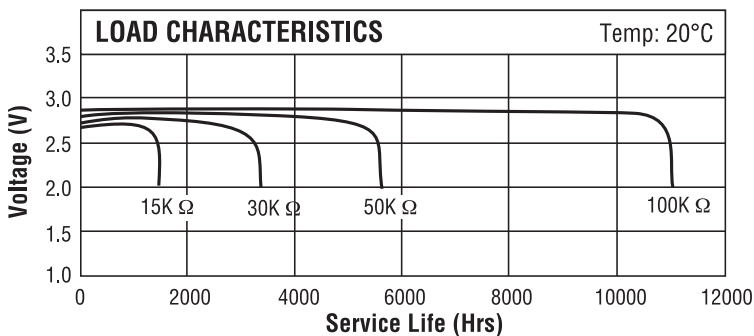

Figure 20

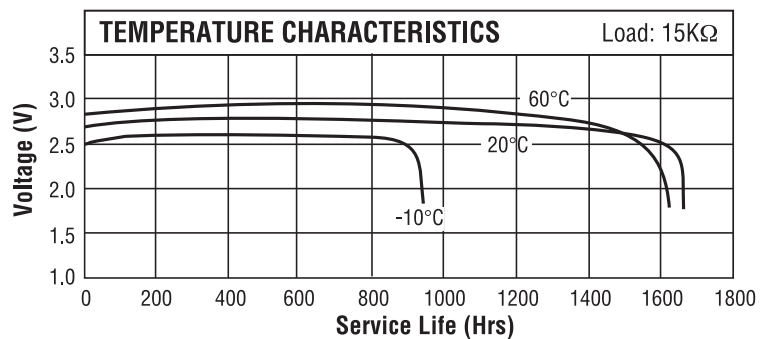

Figure 21

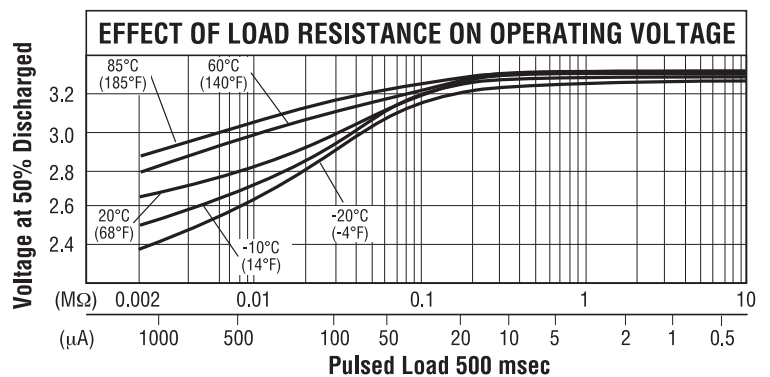

Figure 22

### C. Dimensional Drawing

For illustration only. Contact Rayovac for complete specifications.

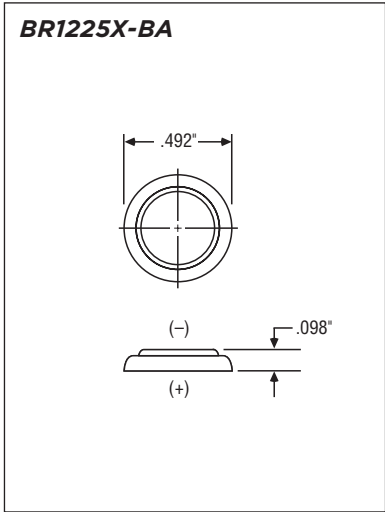

Figure 23

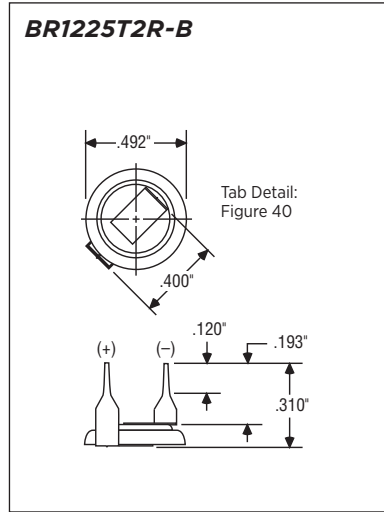

Figure 24

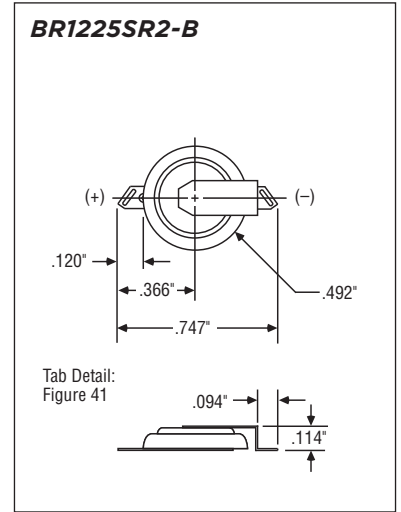

Figure 25

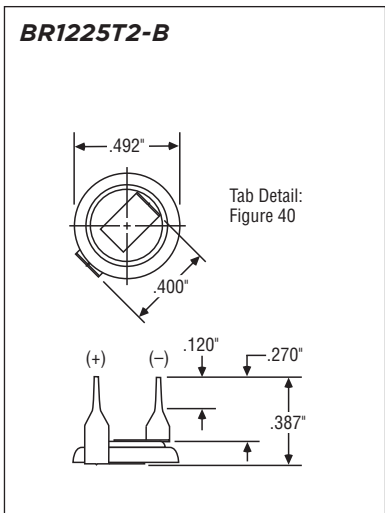

Figure 26

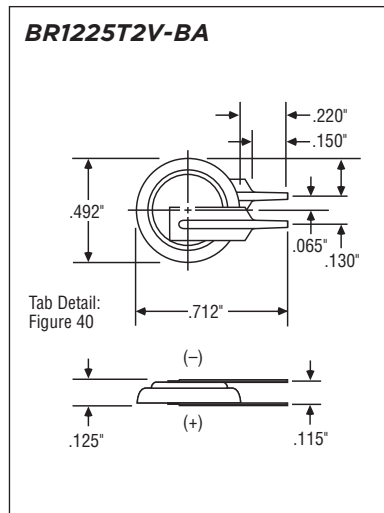

Figure 27

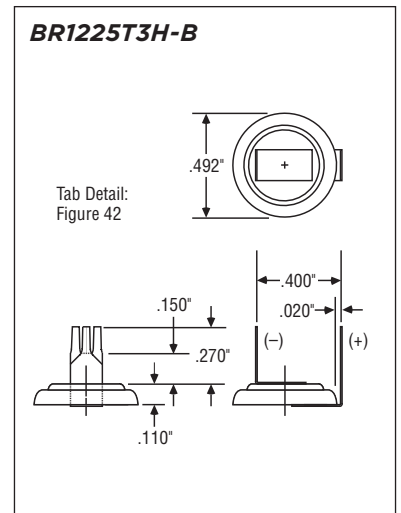

Figure 28

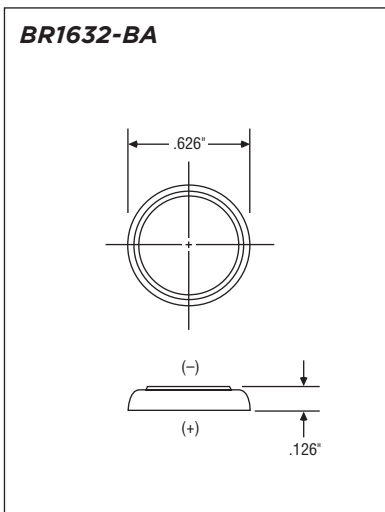

Figure 29

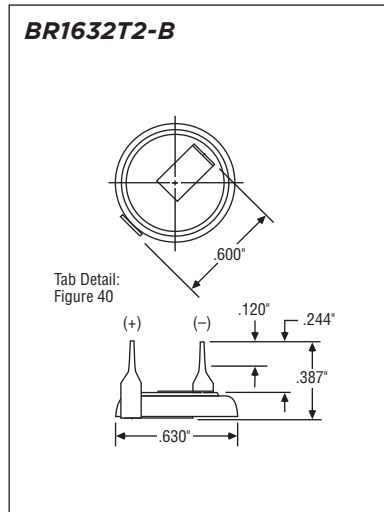

Figure 30

Please Note: Current Rayovac® BR Lithium products are not compatible with Surface Mount Technology (SMT) soldering processes due to the extreme temperatures required for reflow. Batteries should be added as a secondary operation.

For illustration only. Contact Rayovac for complete specifications.

**BR1632R81-BA**

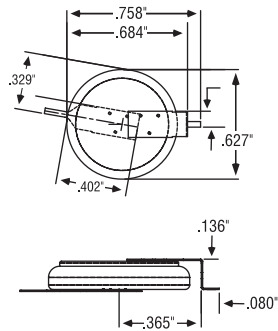
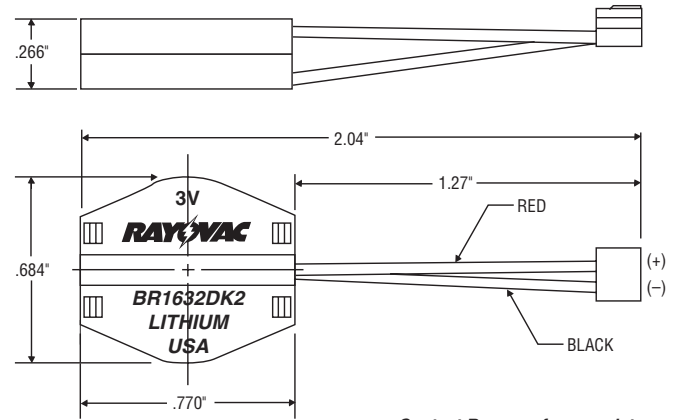

Figure 31

**BR1632DK2-BA**



Contact Rayovac for complete connector detail and specs.

Figure 32

**Conversion Chart**

Inches	Millimeters	Inches	Millimeters	Inches	Millimeters
0.020	0.51	0.220	5.59	0.626	15.90
0.065	1.65	0.231	5.91	0.630	16.12
0.094	2.39	0.242	6.14	0.684	17.37
0.098	2.49	0.244	6.20	0.700	17.78
0.102	2.59	0.266	6.76	0.712	18.08
0.110	2.79	0.270	6.86	0.747	18.97
0.114	2.90	0.288	7.32	0.770	19.56
0.115	2.92	0.300	7.62	0.787	19.99
0.120	3.05	0.310	7.87	0.800	20.32
0.125	3.18	0.357	9.07	0.817	20.75
0.126	3.20	0.359	9.12	0.898	22.81
0.130	3.30	0.366	9.30	0.928	23.57
0.138	3.51	0.387	9.90	0.984	24.99
0.150	3.81	0.400	10.16	1.018	25.90
0.153	3.89	0.415	10.54	1.130	28.70
0.154	3.91	0.417	10.59	1.250	31.80
0.180	4.57	0.492	12.50	1.270	32.30
0.193	4.90	0.550	13.97	2.040	51.82
0.200	5.08	0.600	15.24		
0.216	5.49	0.625	15.88		

Please Note: Current Rayovac® BR Lithium products are not compatible with Surface Mount Technology (SMT) soldering processes due to the extreme temperatures required for reflow. Batteries should be added as a secondary operation.

For illustration only. Contact Rayovac for complete specifications.

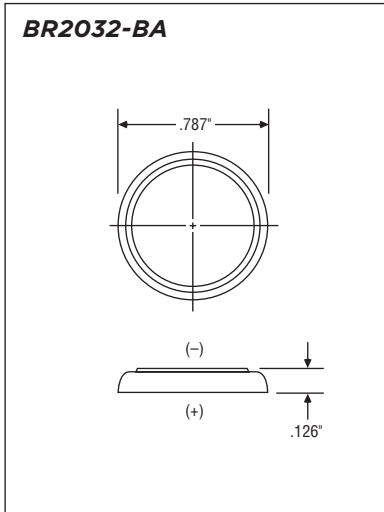

Figure 33

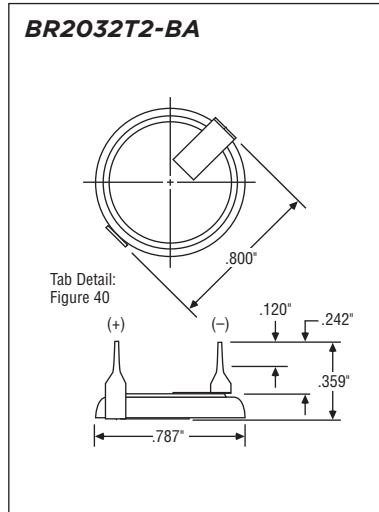

Figure 34

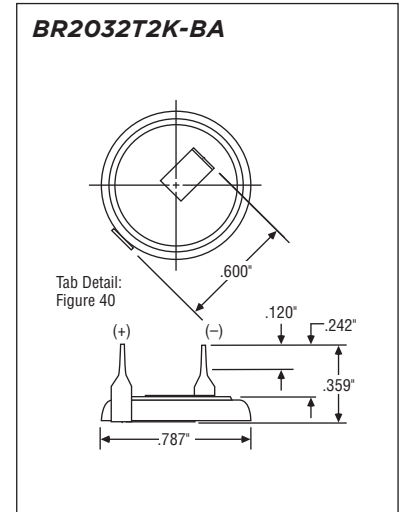

Figure 35

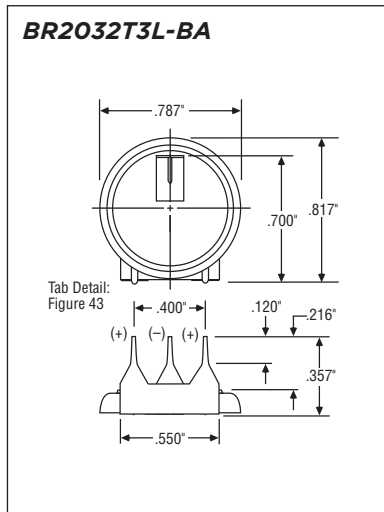

Figure 36

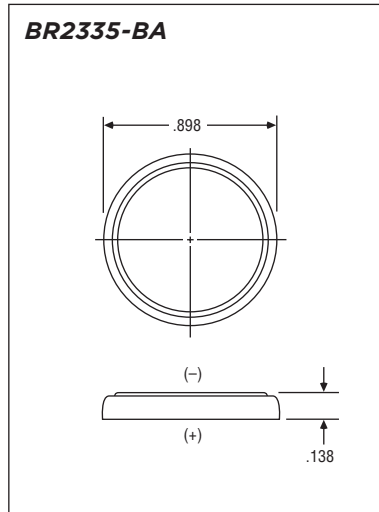

Figure 37

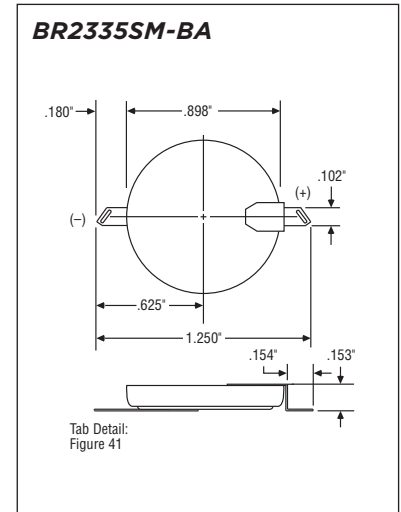

Figure 38

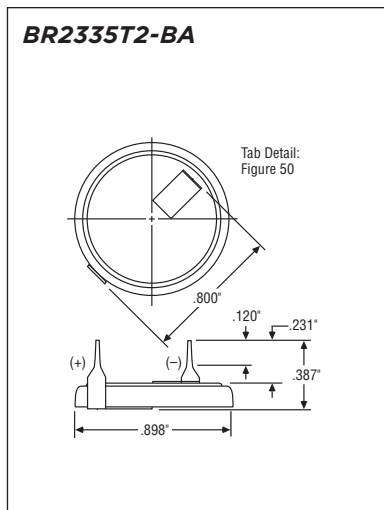

Figure 39

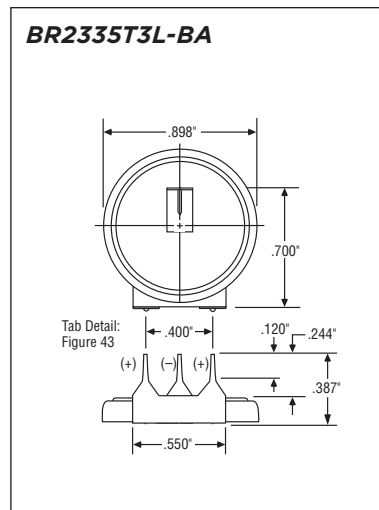

Figure 40

Please Note: Current Rayovac® BR Lithium products are not compatible with Surface Mount Technology (SMT) soldering processes due to the extreme temperatures required for reflow. Batteries should be added as a secondary operation.

## Tab and Pin Detail

For illustration only. Contact Rayovac for complete specifications.

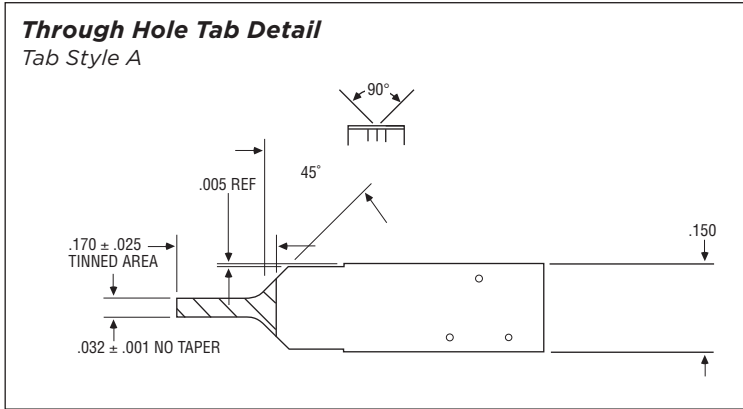

Figure 41

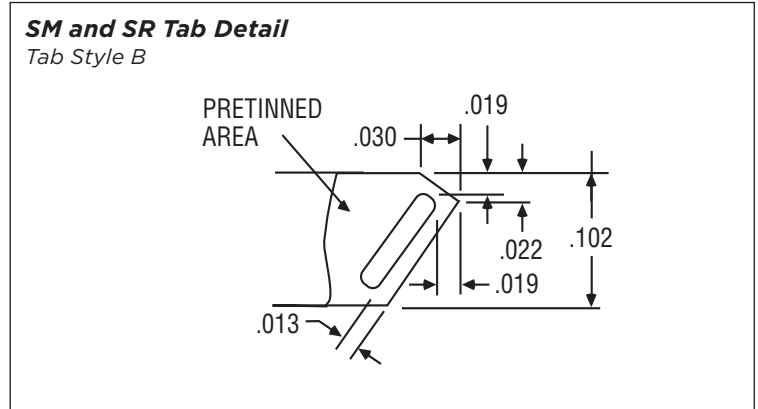

Figure 42

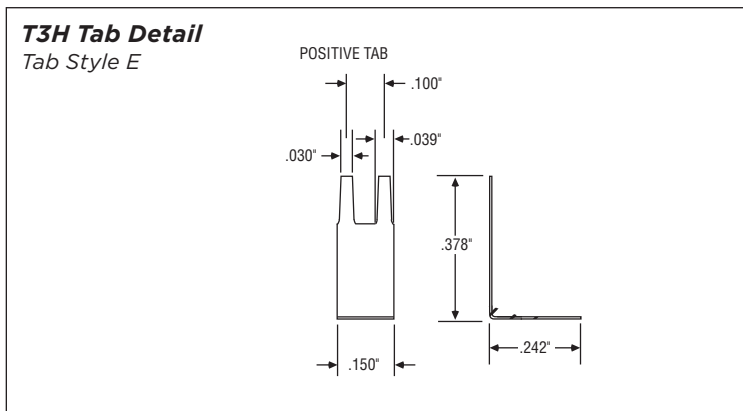

Figure 43

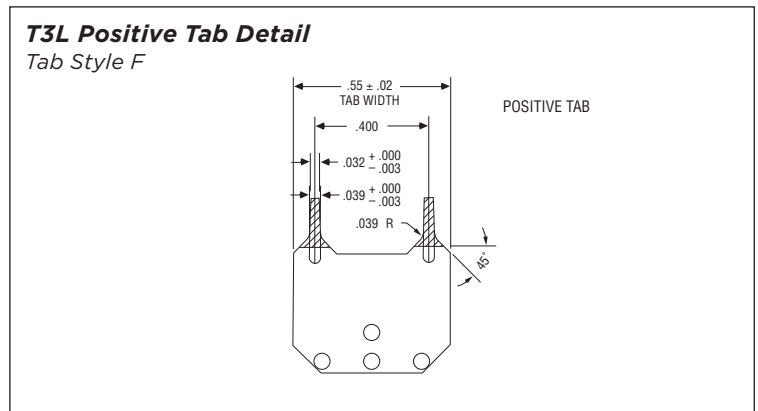

Figure 44

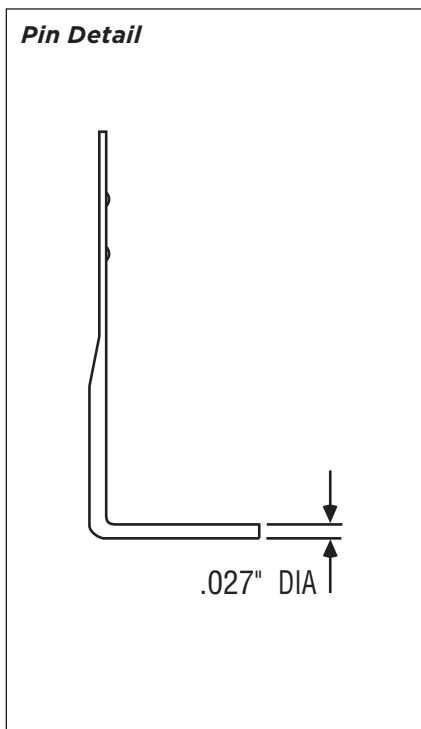

Figure 45

Please Note: Current Rayovac® BR Lithium products are not compatible with Surface Mount Technology (SMT) soldering processes due to the extreme temperatures required for reflow. Batteries should be added as a secondary operation.

## ***X: Product Availability & Cross Reference Table***

<b>Stock Number</b>	<b>Description</b>	<b>Interchangeable Numbers</b>	<b>Figure Numbers</b>	<b>Tab Style</b>	<b>Case Quantity</b>
BR1225X-BA	3.0 volt, 50 mAh coin cell	BR1225	23	N/A	1,680
BR1225T2R-B	BR1225 with 2 tabs	-	24	A	1,000
BR1225SR2-B	BR1225 Surface Mount Style	-	25	B	1,540
BR1225T2-B	BR1225 with 2 tabs	BR1225-1HB	26	A	800
BR1225T2V-BA	BR1225 with 2 tabs - Vertical Mount	BR1225-1VB	27	A	1,690
BR1225T3H-B	BR1225 with 2 tabs, 3 stands - Horizontal Mount	-	28	E	1,000

BR1632-BA	3.0 volt, 130 mAh coin cell	-	29	N/A	740
BR1632T2-B	BR1632 with 2 tabs	-	30	A	800
BR1632R81-BA	BR1632 Surface Mount Style	-	31	A	1,000
BR1632DK2-BA	BR1632 - Leaded coin cell	-	32	N/A	528

BR2032-BA	3.0 volt, 195 mAh coin cell	BR2032	33	N/A	680
BR2032T2-BA	BR2032 with 2 tabs	BR2032-1HE1	34	A	500
BR2032T2K-BA	BR2032 with 2 tabs	BR2032-1HSE*	35	A	539
BR2032T3L-BA	BR2032 with 2 tabs, 3 stands	BR2032-1GS**	36	F	500

BR2335-BA	3.0 volt, 300 mAh coin cell	BR2330**	37	N/A	560
BR2335SM-BA	BR2335 Surface Mount Style	-	38	B	450
BR2335T2-BA	BR2335 with 2 tabs	BR2330-1HE**	39	A	500
BR2335T3L-BA	BR2335 with 2 tabs, 3 stands	BR2330-1GU**	40	F	500

\* Suffix "A" is to designate new case quantity

\* Suffix "B" designates bulk packaged

\*\* Height difference - closest equivalent

## XI: FB Lithium Carbon-monofluoride Batteries



Rayovac® FB batteries consist of two Lithium Carbon-monofluoride coin cells encapsulated within a glass filled polyester molded housing. The FB series of batteries are configured to allow for series or parallel interconnection between the cells.

FB batteries utilize Rayovac® BR Lithium Carbon-monofluoride technology to assure the greatest reliability at very wide temperatures and the lowest self-discharge rate.

### A. Features

- Meets or exceeds typical hermetically sealed battery shelf life vs. temperature capability
- Operating Temperature Range:  
-40°C to +100°C (-40°F to +212°F)
- PCB mountable, wave solderable, and process tolerant
- Inherently safe chemistry
- Application flexibility
- Robotically placeable

### B. Typical Applications

- Time/data protection
- Industrial control
- Communication equipment
- Application flexibility
- Portable Instruments

### C. Specification Table

Part Number	Nominal Voltage (volts)	Nominal Capacity (mA)	Nominal Pulse Capacity (mA*)	Dimensions				
				Width	Length	Height**	Weight	Volume
FB1225H2	3.0 Parallel 6.0 Series	100 Parallel 50 Series	16 Parallel 8 Series	15.9 mm (0.625")	15.9 mm (0.625")	10.3 mm (0.405")	4.2 g (0.15 oz.)	2.00 cc (6.12 in <sup>3</sup> )
FB2032H2	3.0 Parallel 6.0 Series	390 Parallel 195 Series	20 Parallel 10 Series	25.4 mm (1.000")	25.4 mm (1.000")	10.8 mm (0.425")	11.9 g (0.42 oz.)	6.14 cc (0.375 in <sup>3</sup> )

\* Consult Rayovac OEM Engineering Division for assistance in determining pulse capability for your application.

\*\* Height above circuit board. NEDA and IEC numbers have not been assigned to FB products.

## D. Typical Discharge Curves

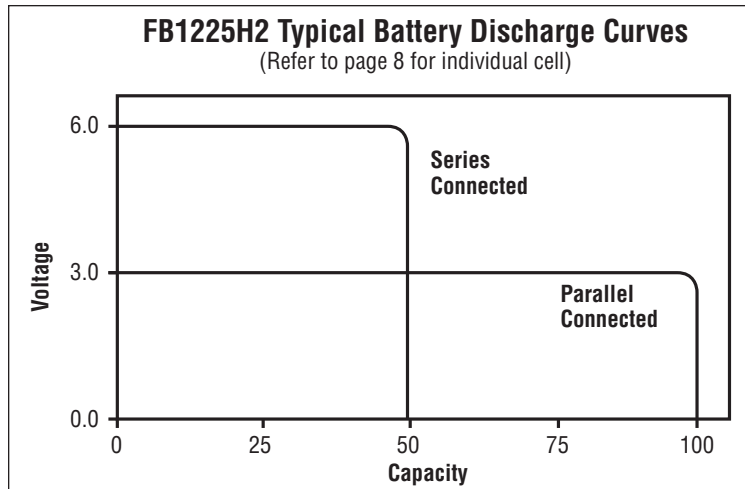

Figure 46

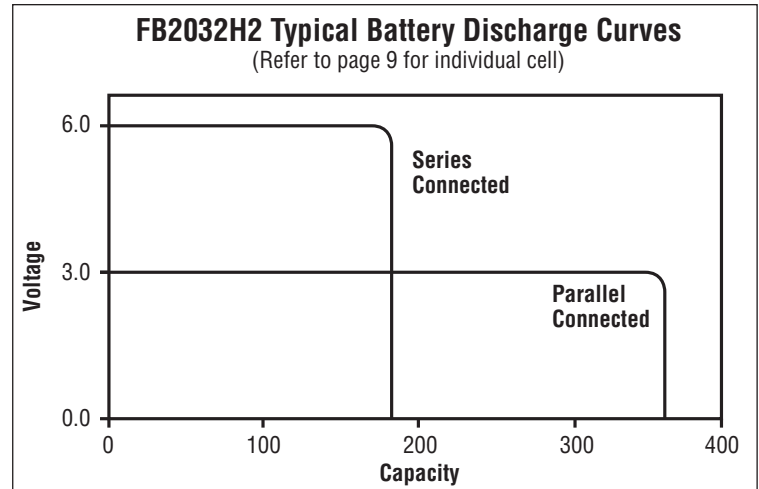

Figure 47

## E. Dimensional Drawing

For illustration only. Contact Rayovac for complete specifications.

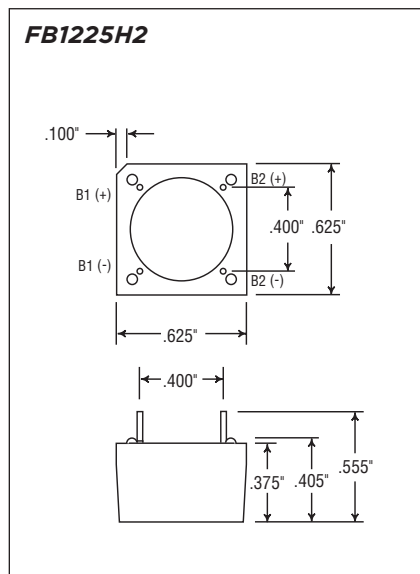

Figure 48

Conversion Chart	
Inches	Millimeters
0.100	2.5
.375	9.5
.395	10.0
.400	10.2
.405	10.3
.425	10.8
.555	14.1
.575	14.6
.625	15.9
.700	17.8
1.000	25.14

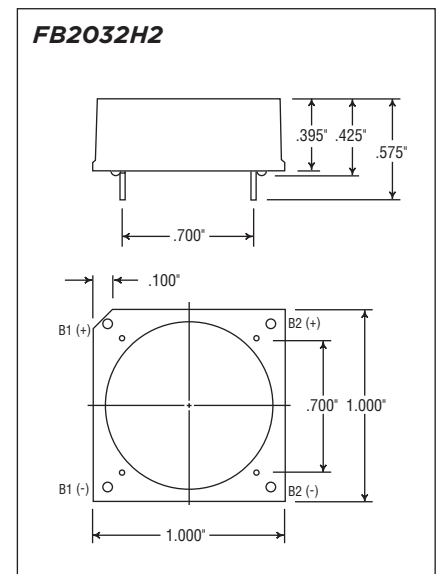
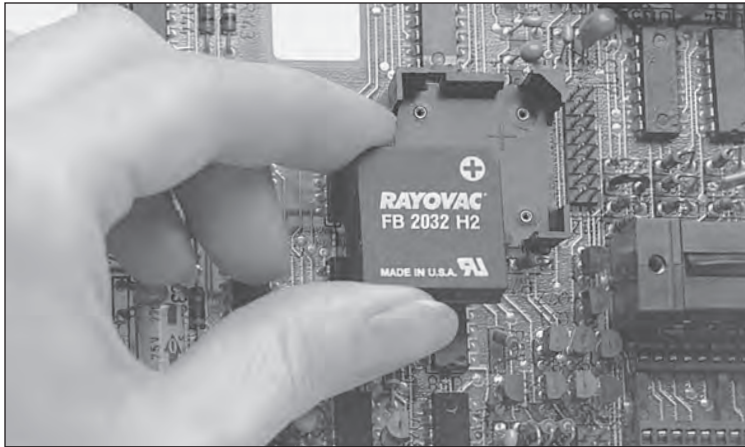

Figure 49

Please Note: Current Rayovac® BR Lithium products are not compatible with Surface Mount Technology (SMT) soldering processes due to the extreme temperatures required for reflow. Batteries should be added as a secondary operation.



## XII: Relex™ Socket



The Relex™ RH20H2 is a printed circuit board mountable battery socket for use with Rayovac's FB2032H2 battery. This device provides excellent component retention and a gas tight, reliable electrical contact. Its self-orienting design assures proper polarity installation without desoldering or the use of special tools.

### A. Features

- Improved contact reliability over conventional holders
- Printed Circuit Board (PCB) mountable, wave solderable, and process tolerant
- Molded in standoff for thorough post reflow cleaning
- Excellent battery retention in shock and vibration
- Tin on tin, gas-tight spring contacts

### B. Dimensional Drawings

For illustration only. Contact Rayovac for complete specifications.

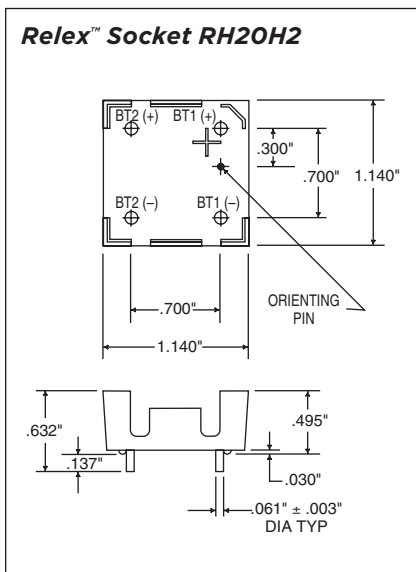

Figure 50

Conversion Chart	
Inches	Millimeters
.003	0.1
.030	0.8
.061	1.5
.137	3.5
.220	5.6
.300	7.6
.495	12.6
.632	16.1
.700	17.8
1.140	28.9

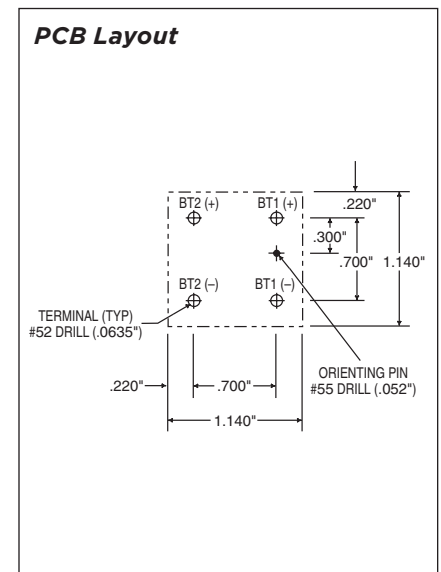

Figure 51

Please Note: Current Rayovac® BR Lithium products are not compatible with Surface Mount Technology (SMT) soldering processes due to the extreme temperatures required for reflow. Batteries should be added as a secondary operation.

## ***XIII: Recommended Storage, Handling and Disposal Procedures***

### **A. Storage and Date Codes**

BR Lithium cells and FB Lithium batteries are electrochemical devices which depend upon internal chemical reactions to produce electrical power. These reactions are accelerated by high temperatures and retarded by low temperatures. Therefore, to minimize power loss during storage, batteries should be stored at ambient temperature, 21°C (70°F). Storage at lower temperatures is not necessary nor recommended due to the possibility of shorting from moisture condensation.

To maximize battery power, the following storage procedures should be observed:

1. Rotate inventory. Maintain a first in, first out method of stock storage and usage. The manufacture date of Rayovac® cells and batteries are identified by a date code stamped on the individual products.
2. Avoid storage in high temperature areas. Make sure that cells and batteries are stored away from hot air vents, radiators, motors, and equipment that generates heat. Avoid storage near windows or skylights where the sun can generate heat.

### **B. General Precautions**

- BR Lithium cells & FB Lithium batteries should not be inserted improperly, recharged, or disposed of in fire
- Take precautions to insure correct polarity of the battery in the device
- Recharging of batteries may cause leakage
- Never short-circuit, disassemble, or subject batteries to excessive heat
- Never expose Lithium to moisture
- Do not solder directly to battery case
- Improper welding can damage internal components and impair battery performance
- Damaged or penetrated batteries could present a fire hazard. Handle all damaged batteries with this caution in mind.

### **C. Handling and Shipping**

Batteries are vulnerable to short circuiting if not handled, packaged, or transported properly. Cell types which have their positive and negative terminations in close proximity to each other, or tabbed cells, are par-

ticularly susceptible to short circuiting if not handled properly. In prototyping and assembly operations, care should be taken to avoid placing these products on conductive antistatic mats.

To avoid potential short circuit and shipping damage situations:

1. Always store the batteries in the trays and/or cartons in which they were shipped. Whenever possible, reship the batteries in undamaged original trays and/or cartons.
2. Rayovac® offers individually packaged cells and batteries, designated by a “-1” suffix on the part number. This allows for the safe handling and transport of batteries in smaller quantities.
3. Never ship batteries or completed circuit boards with installed batteries in anti-static bags as the bags are conductive and will short out the battery.
4. Use caution with measuring equipment. Insulate metal micrometers and calipers with tape to avoid short circuiting batteries during dimensional checks.
5. Make sure batteries installed in equipment are securely or permanently installed prior to packaging.

### **D. Transportation Regulations**

Transportation of Lithium batteries is regulated by the U.S. Department of Transportation (USDOT), the International Civil Aviation Organization (ICAO), International Air Transport Association (IATA) and the UN International Maritime Organization (IMO). For Rayovac® BR and FB solid cathode Lithium metal coin cells and batteries, the quantity of Lithium metal is one of two key determinants that define the applicable regulations and requirements with the other key being the mode of transportation.

For the Lithium quantity: Rayovac® BR Lithium coin cells contain less than 0.5 grams of Lithium metal and Rayovac® FB Lithium batteries contain less than 1.0 gram of Lithium metal.

All of Rayovac’s BR Lithium cells and FB Lithium batteries meet the following requirements:

## 1. Ground/Domestic

- a. USDOT Code of Federal Regulations, Title 49, Part 173.185 and special provision 188. USDOT requires a label on all shipping cartons shipped into, out of or within the US noting the Lithium metal cells/batteries are forbidden on passenger aircraft, even on those cartons shipped only via highway, rail or vessel transportation. See special provisions 188 and A100.

These Rayovac® cells and batteries must be packaged in an inner carton and a strong shipping carton meeting the requirements of part 178, subparts L and M at the Packing Group II performance level. They must be packed in a manner to prevent short circuits including movement that could lead to short circuits.

## 2. Air

ICAO and IATA, Packing Instruction (PI) 968, Section 2 for Lithium metal batteries alone. (Also see PI 969 for batteries packed with equipment

and PI 970 for batteries contained in equipment.) Lithium metal cells & batteries shipping alone or with equipment require the Lithium battery warning label on the shipping carton. (Check PI 970 for when the label is required for batteries contained in equipment.)

These Rayovac® cells and batteries must be packaged in an inner carton and a strong shipping carton meeting the requirements of 5.0.2.4, 5.0.2.6.1, and 5.2.1.2.1. They must be completely enclosed and packed in a manner to prevent short circuits including contact with conductive materials within the carton that could lead to a short circuit.

## 3. Ocean

International Maritime Dangerous Goods Code (IMDG), Amendment 34-08. See special provision 188 and 230. The Rayovac® cells and batteries must be packed in strong shipping cartons and packed to prevent short circuits.

## 4. ROHs compliant Lead Free (pb Free)

## Transportation Regulations

The table below summarizes the specific requirements for each agency.

	United States	International
<b>Regulatory Agency</b>	U.S. Department of Transportation (DOT)	1. International Civil Aviation Organization (ICAO) 2. International Air Transportation Association (IATA)
<b>Regulation</b>	Title 49 CFR 173.185	IATA Dangerous Goods Regulations
<b>Authorized Modes of Transportation</b>	All modes (Air - by cargo aircraft only)	Air
<b>Testing Required</b>	These Rayovac® cells and batteries have passed the UN Model Regulations, Manual of Test and Criteria, Part III, subsection 38.3	These Rayovac® cells and batteries have passed the UN Model Regulations, Manual of Test and Criteria, Part III, subsection 38.3
<b>Special Packaging</b>	Use an inner carton inside a strong outer shipping carton	Use an inner carton inside a strong outer shipping carton. Gross weight can be no more than 2.5 kg
<b>Hazard Class and Required Shipping Name</b>	UN3090, Class 9 but exempted by special provision 188	UN3090, Class 9 but exempted by meeting the requirements of packaging instruction 968, Section 2
<b>Labels Required</b>	Forbidden on passenger aircraft - all. Lithium warning label - air	Lithium warning label Forbidden on passenger aircraft - US
<b>Lithium Metal Limits</b>	Cells: 1.0 gram Batteries: 2.0 grams	Cells: 1.0 gram Batteries: 2.0 grams

## E. Disposal

This statement is provided as a service to those who may want information concerning the safe disposal of waste Rayovac® BR and FB (Lithium Carbon-monofluoride) battery products for the USA. These products may be distinguished from other battery products by the presence of the letters BR or FB in the product designation, and are manufactured in a disk or “coin” shape and square modules.

This information does not apply to any other Lithium chemistry or Lithium Carbon-monofluoride products in other form factors.

**Note:** Where regulations regarding management of spent/waste Lithium batteries exist outside of the USA, they generally differ significantly from United States regulations. For information regarding recommended disposal and management practices in regions or countries other than the USA, please contact Rayovac® at 1-800-237-7000 within the USA, or 608-275-3340 if outside the USA.

Regarding Rayovac® BR Lithium cells and FB Lithium battery waste battery management in the USA: Waste BR Lithium cells and FB Lithium batteries are neither listed nor exempted from the USEPA hazardous waste regulations. Waste BR and FB Lithium products can be considered reactive hazardous waste if there is a significant amount of unreacted, or unconsumed Lithium remaining. This potential problem may be avoided by discharging waste cells and batteries prior to disposal. One tested method for doing this is to place small quantities of BR Lithium cells or FB Lithium batteries into a metal container with sufficient graphite to cover and surround the individual cells.

This procedure will discharge the cells in approximately two weeks to the point where no reactive Lithium remains. The cells may then be disposed of as non-hazardous waste in an ordinary landfill under Federal regulations. The graphite can be reused many times, as needed, or can be disposed of as nonhazardous waste.

### **Other Disposal Methods**

For a list of facilities with demonstrated ability to manage waste BR Lithium cells and FB Lithium battery products as hazardous waste, please [click here](#). The list is not guaranteed to be all inclusive, nor does it seek to exclude potential service suppliers. Rayovac® provides it as a customer service to assist the customer in determining what their management options could be. Always review your choice of firm before sending wastes.

## Cautions

Under United States Federal law, waste generators are responsible for their wastes. Be sure to check your regional, national, or local regulations as they may differ significantly. Always remember that waste battery products may still have considerable energy remaining in them. Handle such products with care and in accordance with applicable USDOT, IATA, or ICAO regulations.

## F. Soldering

Rayovac’s BR and FB component class Lithium batteries are suitable for direct soldering onto printed circuit boards (PCB). A welded tab or pin soldered to a PCB will ensure the highest contact reliability available. Observe these precautions to assure life-of-product reliability:

### **1. Hand Soldering**

Never solder directly to cell cases. The resultant heat will cause permanent internal damage to the cell. Soldering of tabbed batteries should be accomplished with a low wattage soldering iron by applying heat just long enough to achieve a good connection.

### **2. Wave Soldering**

During the period when the battery tabs or pins are in the solder bath, the battery is short circuited. If this period is kept to under 5 seconds the battery capacity loss will be minimized. Following a short circuit the battery voltage will recover to above 2.5 volts almost immediately while full recovery to its final working voltage may take hours or even days. This characteristic must be taken into account when making electrical measurements on recovering batteries or when establishing manufacturing pass/fail points.

### **3. Surface Mount Technology**

Rayovac® offers a full line of surface mount Lithium cells configurations. These cells are indicated by the suffix “SM” or “SR” in the stock number. The surface mount batteries have configurations that allow for easy board mounting.

Current BR and FB Lithium products are not compatible with Surface Mount Technology (SMT) soldering processes due to the extreme temperatures required for reflow. Batteries should be added as a secondary operation. Mixed technology boards that utilize both SMT and traditional through-hole components have been successfully fabricated.

## G. Washing

It is important that PCB wash techniques are compatible with Rayovac's Lithium BR and FB batteries. The seals of these batteries are polypropylene and solvents that attack this material should be avoided. The most common Freon types and deionized water have shown to be acceptable cleaning solvents. Rayovac should be consulted if there is any possibility of process related battery damage.

## XIV: U.L. Component Recognition

Rayovac® BR Lithium batteries have been accepted by Underwriters Laboratories under their Component Recognition Program and carries U.L. File Number MH 12542. All recognized Lithium batteries can be identified by the  symbol located on the data sheet. For use in UL listed devices, these Lithium batteries must be used in accordance to the following U.L. conditions of acceptability.

### A. Conditions of Acceptability

The use of these cells may be considered generally acceptable under the conditions given below:

1. The cells are identified with producer's name and model designation on the cell.
2. These cells are intended for use as components in devices where servicing of the circuitry involving the cells and replacement of the Lithium cells will be done by a trained technician.
3. These cells are intended for use at ordinary temperatures where anticipated high temperature excursions are not expected to exceed 100°C (212°F).
4. These cells can be used in series up to a maximum of four cells of the same model number. When used in series, they should all be replaced at the same time using fresh cells only. These cells should not be connected in series with any other (other than the allowed number of cells in series) power source that would increase the forward current through the cells
5. The circuit for these cells should include one of the following:
  - A. Two suitable diodes or the equivalent in series with the cells to prevent any reverse (charging) current. The second diode is used to provide protection in the event that one should fail. Quality control, or equivalent procedures shall be established by the device's manufacturer to insure the diode polarity is correct for each unit.

- or -

- B. A blocking diode or equivalent to prevent reverse (charging) current, and in the event of diode failure, the cell shall be further protected against reverse (charging) current in excess of the values shown in chart to the right. The measurement of this current shall include appropriate abnormal tests.

### Maximum Reverse Charging Currents for Rayovac® BR Lithium Coin Cells

Cell Models	Maximum Current (mA)
BR1225	3.0
BR1632	3.0
BR2023	4.0
BR2335	5.0
FB1225	3.0

Please Note: Current Rayovac® BR Lithium products are not compatible with Surface Mount Technology (SMT) soldering processes due to the extreme temperatures required for reflow. Batteries should be added as a secondary operation.

## B. Protective Battery Circuits

For D1/D2 use Low reverse leakage current Silicon diodes.  
Do not use low power Schottky diodes.

*Protective Redundant Diodes*

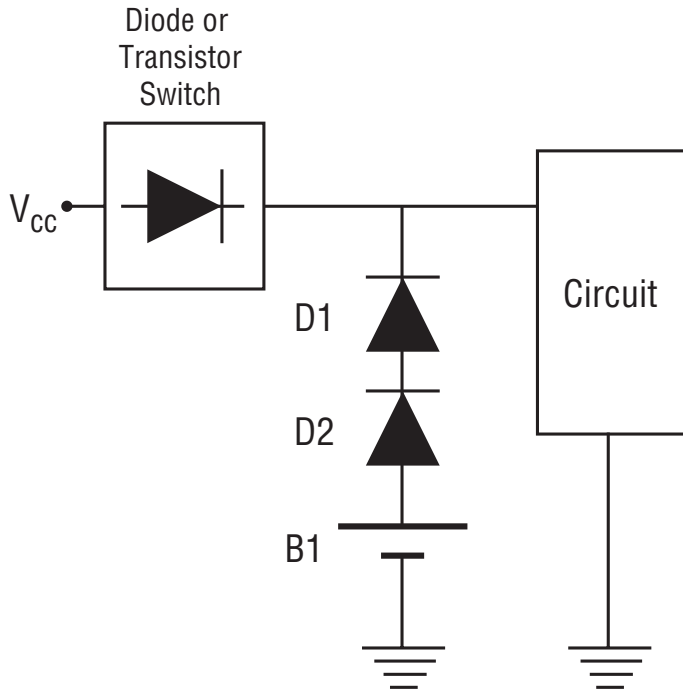

*Protective Diodes and Limiting Resistor*

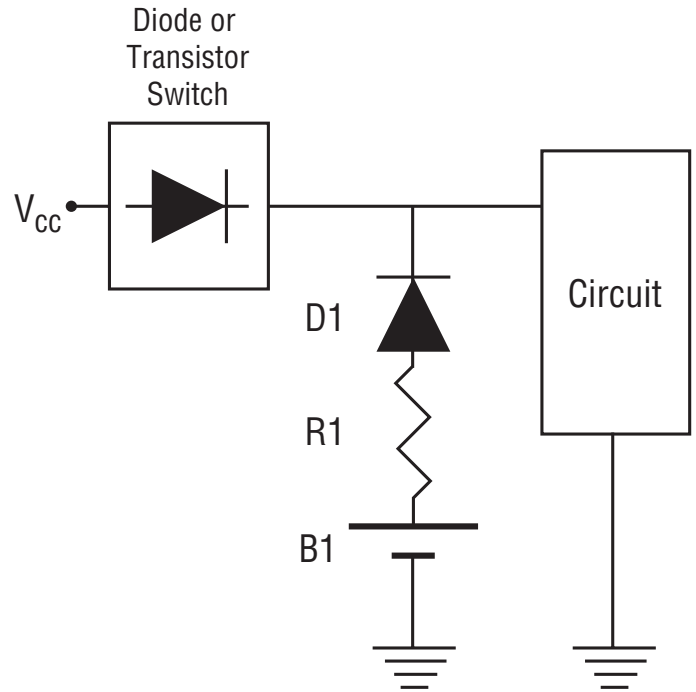

### Notice

This publication is furnished only as a guide. It is the user's responsibility to determine suitability of the products described for the user's purpose (even if the use is described herein) and to take precautions for protection against any hazards attendant to the handling and use of the products. Rayovac® recommends prospective users test each application.

The battery products and arrangements described herein may be covered by patents owned by Rayovac® or others. Neither this disclosure nor the sale of products by Rayovac® conveys any license under patent claims covering combinations of battery products with other elements or devices. Rayovac® does not assume liability for patent infringement arising from any use of the products by the purchaser.

The technical data contained herein are not designed to be the basis for specifications. Rayovac's OEM Engineering Division can furnish data that can serve as the basis for specifications.

