

Dedicated C&I / Utility ESS



Self-Consumption



Demand Charge



Micro-grid



EV charge Station



Frequency Integration



Off Grid



V2G



Back Up



Peak Shifting



Renewable Regulation



Battery

storage systems have been proven to be “extremely lucrative”
for commercial and industrial (C&I) field.

“ MAXIMUM SAFETY FOR YOUR ENERGY

Providing a continuous and reliable supply of power from a flexible mix of conventional and renewable sources is the goal of power generation in the energy evolution.

C&I/Utility ESS Key Features



Vertical industry Integration Chain



Three-levels monitoring and management mechanism design



Optimal Electricity Long cycle life and superior performance



Rack mounted or container based system configuration

UL9540A Test Summary

- Target BESS temperature less than gas vent temperature
- Temperature increase of target walls less than 97 °C 175 °F)
- The flame indicator shall not propagate flames beyond the width of initiating BESS
- No flaming outside the test room

Certification

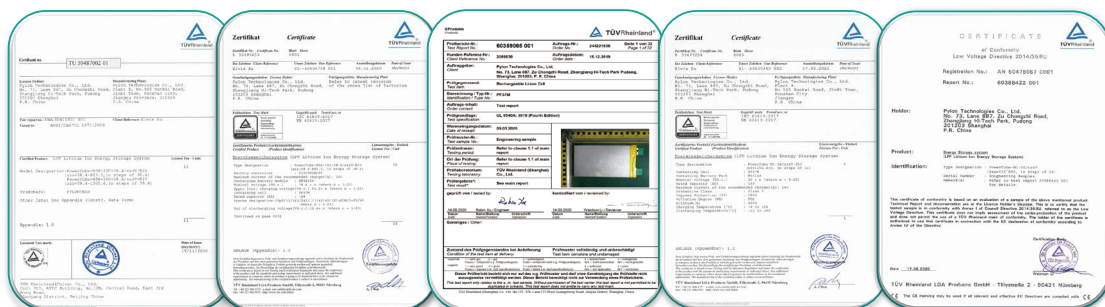

UL1973

IEC62619

UL9540A

IEC63056

VDE



Power Distribution

Back Up

Battery energy storage system (BESS) serves as ideal back-up for instant power supply, Seamless Switch to off grid mode in the very short time and realize the Uninterruptible power supply.

How it benefit?

Avoid devices stop working and reduce economic losses once outage or disconnection from the grid.

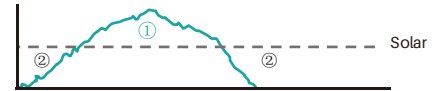
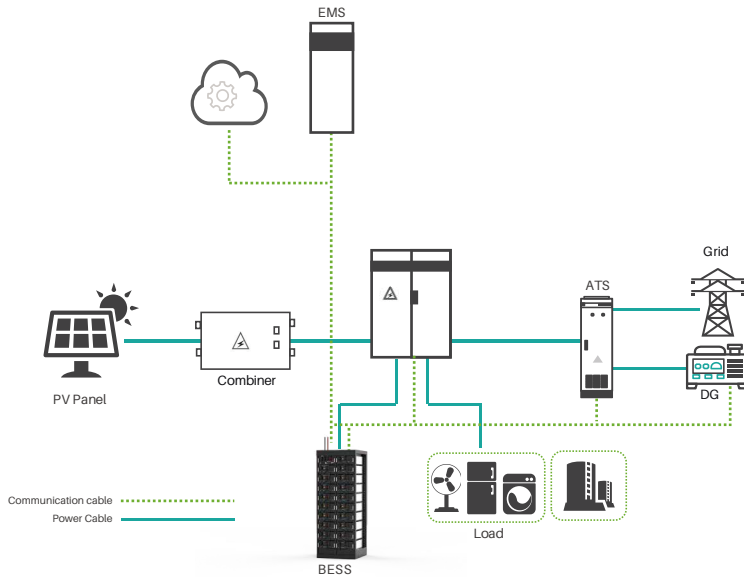

- ① When solar is sufficient, solar charge the battery and power battery.
- ② When the solar is weak, Battery power the load.



When grid fails or cloudy day, battery power the load.



When battery in low mode, DG start to power the load.



Continuous Power to the load

EV Charge Station/V2G

Uncontrolled charging demand in an electric vehicle charging station (EVCS) can potentially result in the overloading of the grid coupling transformer and affect the transformer's lifetime. BESS in PV integrated EV charging station for reducing transformer overloading and providing battery-to-grid service

How it benefit?

Delay the investment of grid structure.

Reduce transformer overloading and PV smoothing within battery SOC constraints.

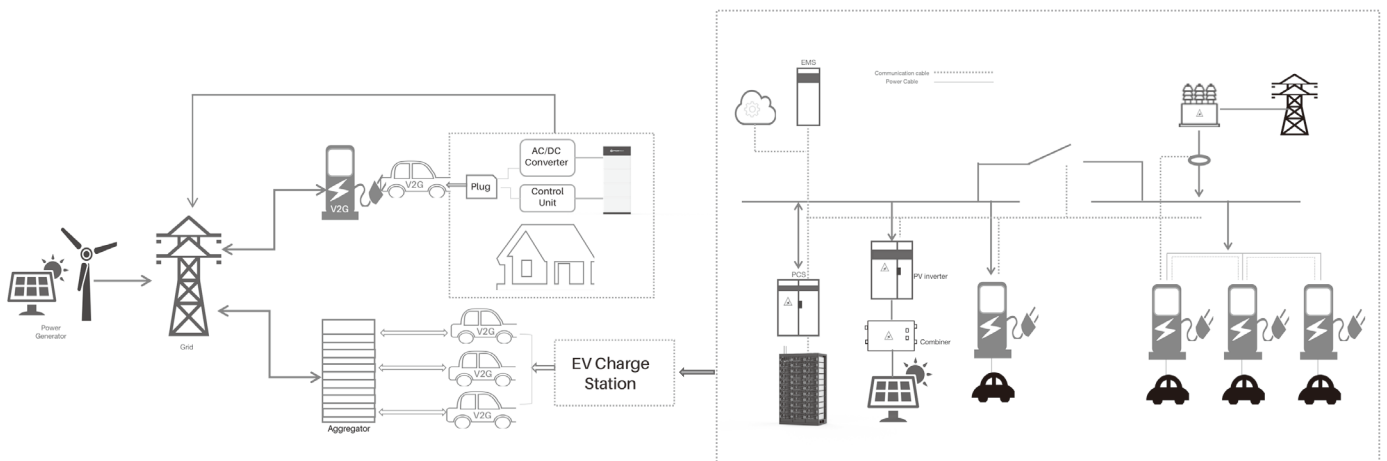

Micro-grid

A microgrid is a self-sufficient energy system that serves a discrete geographic footprint, such as a college campus, hospital complex, business center, rural areas, shop or island use.

How it benefit?

- Operate independently
- Avoid high cost to expand a grid connection
- Save electric bill

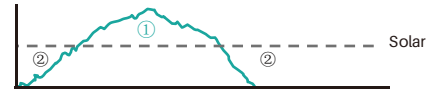
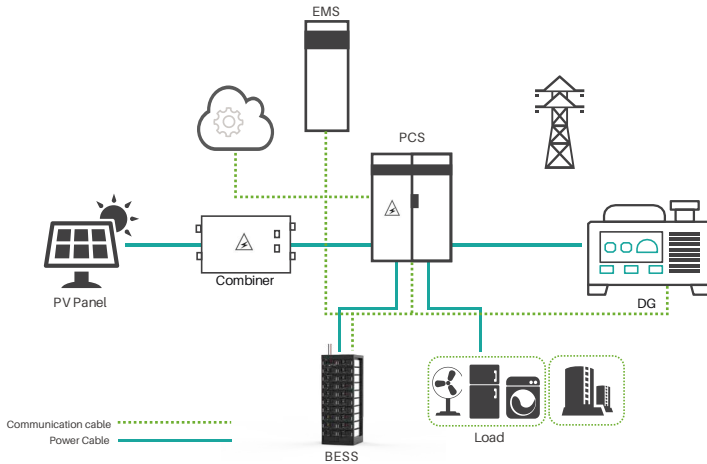

- ① When solar is sufficient, solar charge the battery and power the load.
- ② When the solar is weak, solar and battery power the load.



When at night or cloudy day, battery power the load.



When battery in low mode, DG start to power the load.



Continuous Power to the load

Large-Scale Off grid

Solar plus storage system will be the main power source to produce and store energy for rural and remote off-grid area. DG as backup to support daily consumption.

How it benefit?

- Safe, low-maintenance power supply
- Reduce fuel cost and air pollution
- Reliable supply without a grid connection

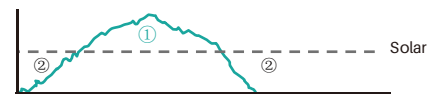
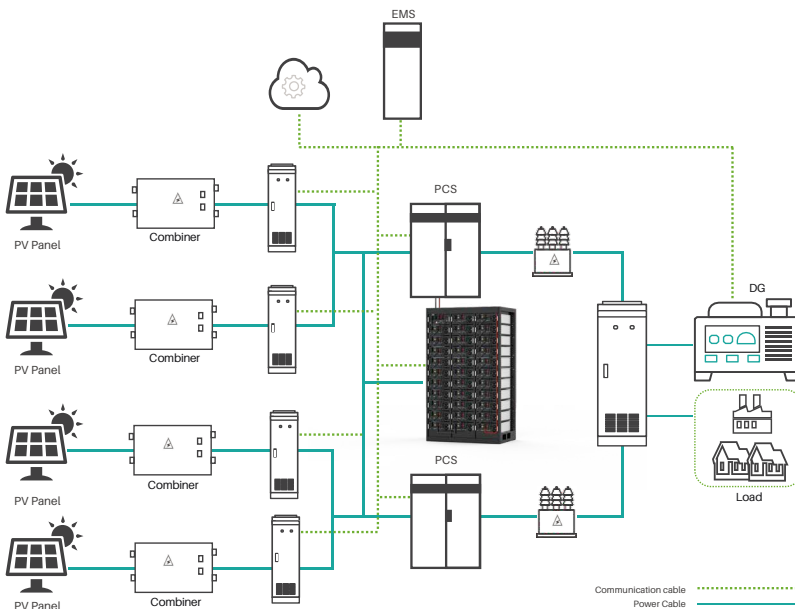

- ① When solar is sufficient, solar charge the battery and power load.
- ② When the solar is weak, solar and battery power the load.



When at night or cloudy day, battery power the load.



Continuous Power to the load

Peak Shifting

With purpose of reducing peak demand and economy of operation, compensate local transformer limit.

How it benefit?

Save on their electricity bills by reducing peak demand (Commercial and industrial customers)

Reduce the operational cost of generating power during peak periods (Utilities)

Investment in infrastructure is delayed due to the flatter loads with smaller peaks (Owner)

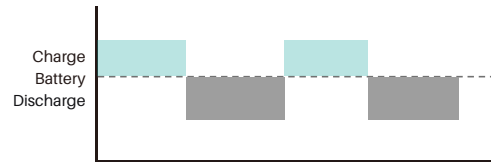
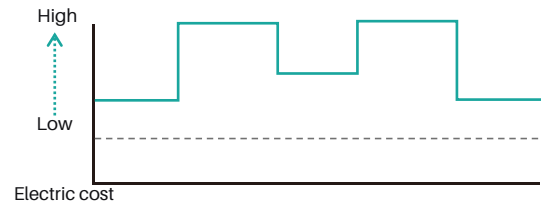
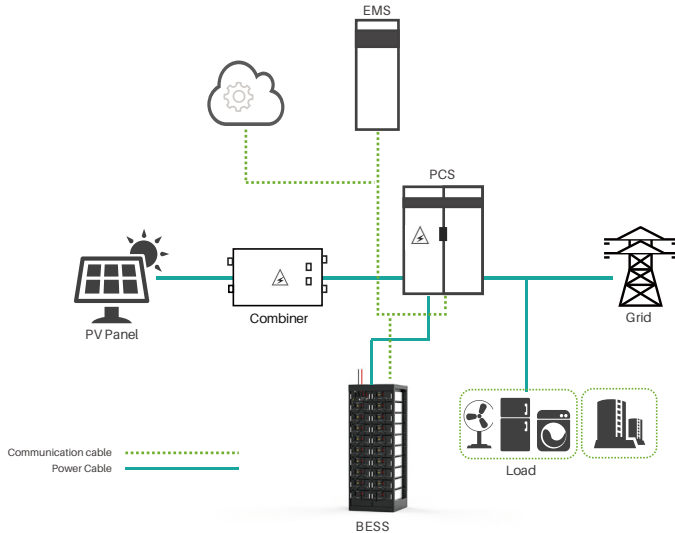

Frequency regulation

BESS will be imperative to ensure that frequency regulating services can be provided when required and meet the charge/discharge requirements imposed on assets providing enhanced frequency response.

How it benefit?

Reduce the investment of power generation, save cost

Constant balancing act to manage system frequency stability.

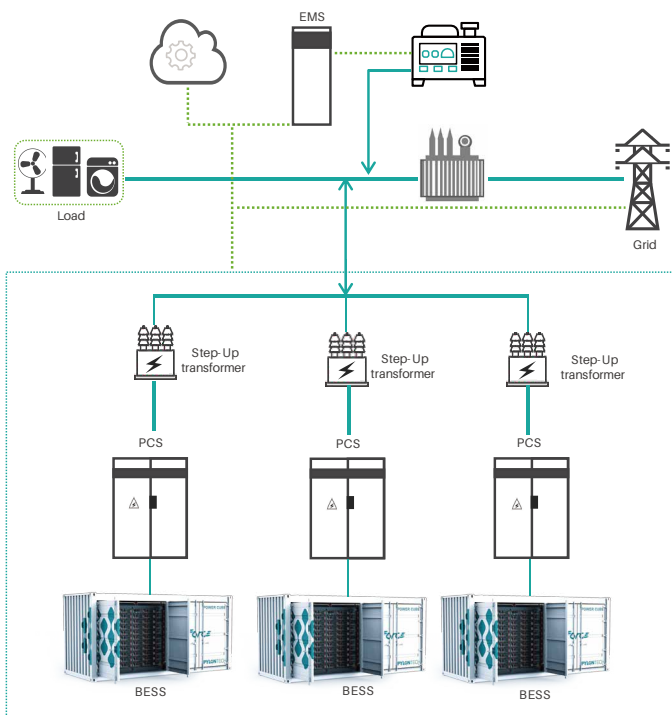

Communication cable
Power Cable

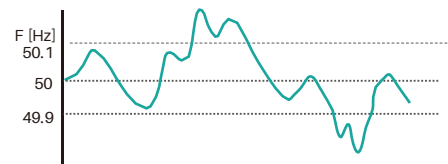

Charge the battery quickly from grid when the energy is abundant, Discharge when the energy is less available, keep regular frequency.

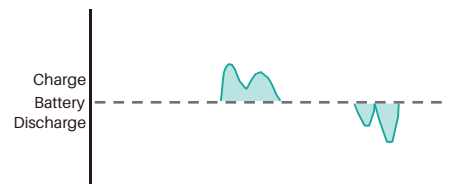

Power Generator



Grid Service

BESS will be imperative to ensure that frequency regulating services can be provided when required and meet the charge/discharge requirements imposed on assets providing enhanced frequency response.

How it benefit?

Reduce the investment of power generation, save cost
Constant balancing act to manage system frequency stability.

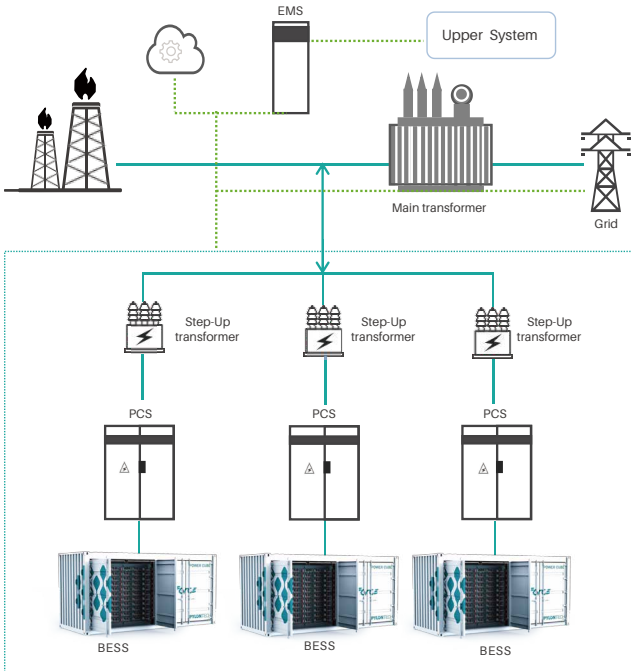

Communication cable
Power Cable

Sequence diagram

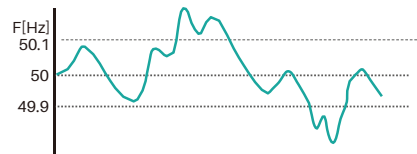

Charge battery from grid when the power is abundant, Discharge battery to compensate power of grid and keep regular frequency.

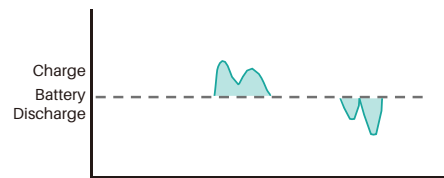

Renewable Integration

Storage helps smooth the power supply, enabling electricity to flow even when the sun isn't shining or the wind isn't blowing. It brings more reliability, more resiliency, and many of these systems can be used for voltage correction, and frequency response in the grid.

How it benefit?

Adding storage to distributed fixed-orientation PV is assumed to increase the capacity credit
Reduce grid investment for renewable energy connection
Reduce grid stress from renewable inrush

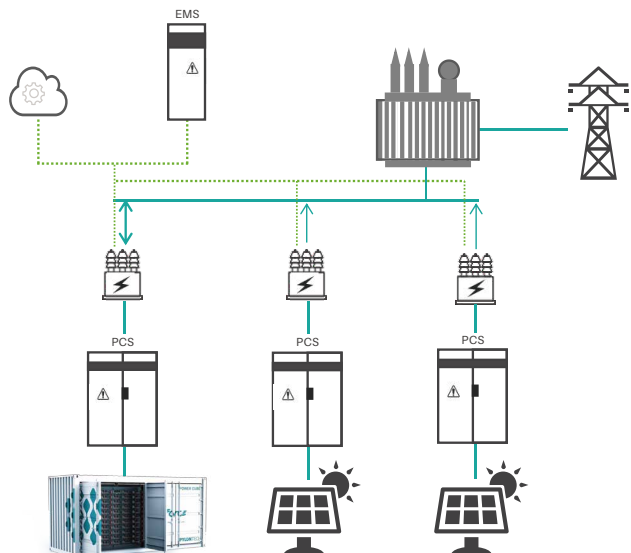

Communication cable
Power Cable

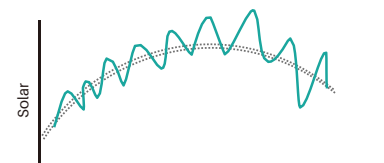

Charge battery from grid when the power is abundant, Discharge battery to compensate power of grid and keep regular frequency.

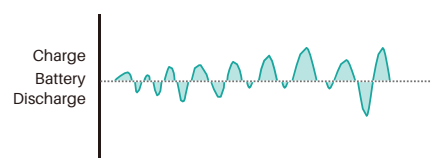

SPECIFICATION

Battery Module



Basic Parameters	H48050	H48074	H32148-C
Energy (kWh)	2.4	3.55	4.74
Nominal Voltage(V)	48	48	32
Battery Capacity(Ah)	50	74	148
Voltage Range(V)	43.5~54	43.5~54	30~36
Dimension (W*D*H mm)	442*390*100	442*390*132	330*628*150.5
Weight(kg)	24	32	48

Powercube X series

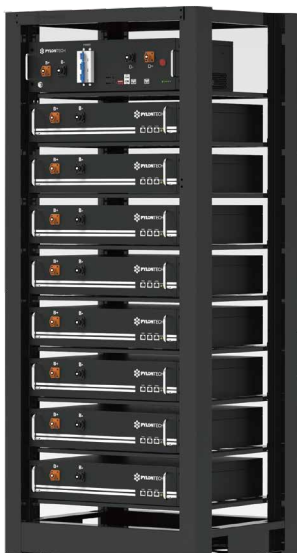

Basic Parameters	Powercube X1 (50Ah)	Powercube X2 (74Ah)
Battery Module	H48050	H48074
Battery System Capacity(kWh)	24	35.5
Battery System Voltage(V)	864	864
Battery System Voltage Range (V)	783~972	783~972
Efficiency(@0.5C-rate)	96%	96%
Depth of Discharge	95%	95%
Cycle Life	>8000, @25 °C	>8000, @25 °C
Design Life	15+Years	15+Years
Operation Temperature (°C)	0~50	0~50
Humidity	5%~95%	5%~95%
Altitude(m)	<2000	<2000
Battery Module Qty.(Optional)	2~18	2~18
Certification	IEC62619/VDE2510-50/UL1973/CE/CEC	
Rack Dimension (W*D*H mm)	600*505*2130	600*505*2130
Weight(kg)	317	397

SPECIFICATION

Powercube H series
200~1000V



Powercube H series
200~1000V

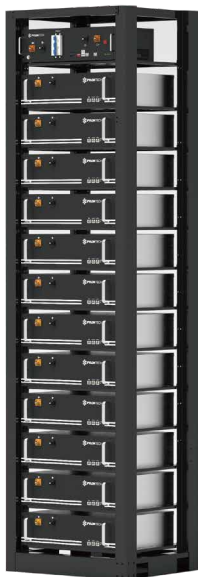

Basic Parameters	Powercube-H1 (50Ah)
Battery Module	H48050
Battery System Capacity(kWh)	36
Battery System Voltage(V)	864
Battery System Voltage Range (V)	783~972
Efficiency(@0.5C-rate)	96%
Depth of Discharge	95%
Cycle Life	>8000, @25 °C
Design Life	15+Years
Operation Temperature (°C)	0~50
Humidity	5%~95%
Altitude(m)	< 2000
Battery Module Qty.(Optional)	5~18
Certification	IEC62619/VDE2510-50/ UL1973/CE/CEC
Rack Dimension (W*D*H mm)	600*505*2130
Weight(kg)	437

Basic Parameters	Powercube-H2 (74Ah)
Battery Module	H48074
Battery System Capacity(kWh)	42.62
Battery System Voltage(V)	864
Battery System Voltage Range (V)	783~972
Efficiency(@0.5C-rate)	96%
Depth of Discharge	95%
Cycle Life	>8000, @25 °C
Design Life	15+Years
Operation Temperature (°C)	0~50
Humidity	5%~95%
Altitude(m)	< 2000
Battery Module Qty.(Optional)	5~18
Certification	IEC62619/UL1973/CE
Rack Dimension (W*D*H mm)	600*505*2130
Weight(kg)	461

SPECIFICATION

Battery Module



Basic Parameters	HM2A180
Energy (kWh)	5.68
Normal Voltage(V)	38.4
Battery Capacity(Ah)	148
Dimension (W*D*H mm)	315*820*171.5
Weight(kg)	55

BMS



Basic Parameters	S1000M2A180	S1000M2A180J
AC Supply for BMS	100-290Vac/50Hz/1.3A	NA
System Operation Voltage (Vdc)	0~1000	0~1000
Dimension (W*D*H mm)	315*710*171.5	
Weight(kg)	19	

Powercube M2



Basic Parameters	Powercube-M2A-180 (148Ah)
Battery Module	HM2A180
Battery System Capacity(kWh)	107.98
Battery System Voltage(V)	883.2
Battery System Voltage Range (V)	800.4~993.6
Efficiency(@0.5C-rate)	96%
Depth of Discharge	90%
Cycle Life	>7000, @25 °C
Design Life	15+Years
Operation Temperature (°C)	10~40
Humidity	5%~95%
Altitude(m)	<2000
Battery Module Qty.(Optional)	1~23
Certification	IEC626 19/CE/UN38.3
Rack Dimension (W*D*H mm)	803*845*2130
Weight(kg)	1228

SPECIFICATION

Battery Module



Basic Parameters	HM3A180
Energy (kWh)	5.68
Normal Voltage(V)	38.4
Battery Capacity(Ah)	148
Dimension (W*D*H mm)	375*820*171.5
Weight(kg)	61

BMS



Basic Parameters	S1000M3A180L	S1500M3A180L	S1000M3A180J
AC Supply for BMS	100~230Vac/50Hz	100~230Vac/50Hz	NA
System Operation Voltage (Vdc)	0~1000	0~1500	400~1000
Dimension (W*D*H mm)	375*710*171.5		
Weight(kg)	13		

Powercube-M3

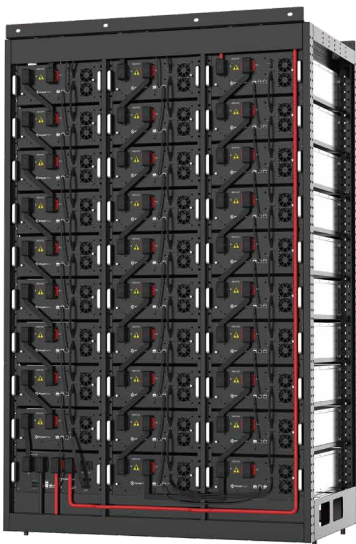

Basic Parameters	Powercube-M3A-180 (148Ah)
Battery Module	HM3A180
Battery System Capacity(kWh)	164.81
Battery System Voltage(V)	1305.6
Battery System Voltage Range (V)	1101.6~1468.8
Efficiency(@0.5C-rate)	96%
Depth of Discharge	90%
Cycle Life	>7000, @25 °C
Design Life	15+ Years
Operation Temperature (°C)	10~40
Humidity	5%~95%
Altitude(m)	<2000
Battery Module Qty.(Optional)	1~34
Certification	UL 1973, UL9540A, IEC62477-1, IEC62619, UKCA, CE LVD, CE EMC, UN38.3, VDE-AR-E 2510-50
Rack Dimension (W*D*H mm)	1365*845*2130
Weight(kg)	1798

SPECIFICATION

Battery Module



Basic Parameters	HM5A180F
Energy (kWh)	15.36kWh
Normal Voltage(V)	64
Battery Capacity(Ah)	240
Dimension (W*D*H mm)	460*900*160.5
Weight(kg)	110

BMS



Basic Parameters	S1000M5A180J	S1500M5A180E	S1500M5A180J
AC Supply for BMS	230Vac/50Hz	230Vac/50Hz	N/A
System Operation Voltage (Vdc)	0~1500	0~1500	450~1500
Dimension (W*D*H mm)	460*858*160		
Weight(kg)	30		

Powercube-M5A-64



Battery System	Powercube-M5A-64 (240Ah)
Battery Module	HM5A180F
Battery System Capacity(kWh)	322.56
Battery System Voltage(V)	1344
Battery System Voltage Range (V)	1131~1491
Efficiency(@0.5C-rate)	96%
Max.Continuous Current(Ah)	180
Peak Current(Amps)	210A@5min/320A@30sec
Over Current/Duration (Amps/ms)	10000A/2ms
Depth of Discharge	95%
Cycle Life	>7000, @25 °C
Design Life	15+Years
Operation Temperature (°C)	10~40
Humidity	5%~95%
Altitude(m)	<4000
Battery Module Qty.(Optional)	1-21
Certification	UL1973, UL9540A, IEC62477-1, IEC62040-1, IEC62619, UKCA, CE LVD, CE EMC, UN38.3, VDE_x0002_AR-E 2510-50、GB36276、GB34131
Rack Dimension (W*D*H mm)	1050*925*2215
Weight(kg)	2520

SPECIFICATION



Mechanical Characteristics	POWERCUBE20HM1		POWERCUBE40HM1	
Battery System	Powercube M1C		Powercube M1C	
System Voltage Range(Vdc)	736(690~828)		736(690~828)	
Charging/Discharging Rate	0.5C		0.5C	
Battery String Amount	12		24	
System Capacity (MWh)	1.421		2.841	
Mechanical Characteristics	POWERCUBE20HM2		POWERCUBE40HM2	
Battery System	Powercube M2		Powercube M2	
System Voltage Range(Vdc)	806(680~907)		806(680~907)	
Charging/Discharging Rate	0.5C		0.5C	
Battery String Amount	12		25	
System Capacity (MWh)	1.432		2.983	
Mechanical Characteristics	POWERCUBE20HM3		POWERCUBE40HM3	
Battery System	Powercube M3		Powercube M3	
System Voltage Range(Vdc)	<1000	<1500	<1000	<1500
Charging/Discharging Rate	0.5~1C		0.5~1C	
Battery String Amount	10	6	22	16
System Capacity (MWh)	1.194	1.091	2.625	2.546
Dimension(L*W*H,M)	6.096*2.438*2.896		12.192*2.438*2.896	
Temperature	-20~60 °C			
Communication port	CANBUS/Modbus TCP/IP			

SPECIFICATION

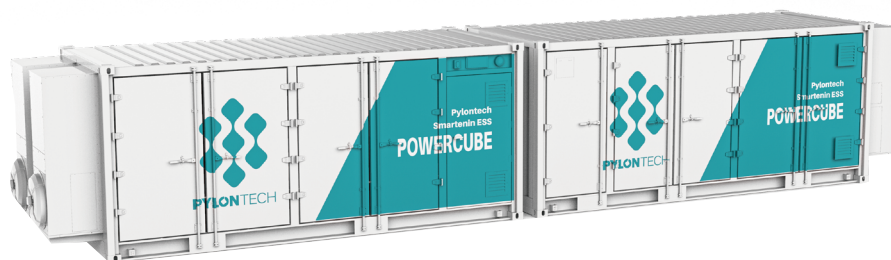

Mechanical Characteristics	POWERCUBE20HM5		POWERCUBE40HM5	
Battery System	Powercube M5		Powercube M5	
System Voltage Range(Vdc)	<1000	<1500	<1000	<1500
System Capacity (MWh)	2.509	2.634	5.108	5.268
Battery String Amount	16	8	32	16
Dimension(L*W*H,M)	6.096*2.438*2.896		12.192*2.438*2.896	
Weight (Ton)	28	27	58	56
Temperature	-20~60 °C			
Communication port	RS485/CAN/Ethernet			



www.pylontech.com
sales@pylontech.com.cn



Pylon Technologies Co., Ltd
No. 71-72, Lane 887, Zu Chongzhi Road,
Zhangjiang Hi-Tech Park Pudong,
Shanghai 201203, China